SuperEvac[®] Vacuum Pump



Operation and Maintenance Manual

Models 93511 - 93516
93540 - 93598

Table of Contents	Page
Features of your new pump.....	3
The purpose of the SuperEvac™ design.....	4
The 7 important steps of initial start-up.....	5
Vacuum tips for best performance.....	5, 6
Basic troubleshooting.....	7
• Four most common problems	
• Oil leakage	
• The steps to solving 95% of all problems	
Diagnostic chart.....	8, 9
Replacement parts.....	10, 11
Warranty and Service.....	12

Important Notices to Purchaser

Check for damage immediately.

Prior to shipment, all YELLOW JACKET® SuperEvac™ vacuum pumps are completely tested and inspected to assure compliance with Ritchie Engineering factory specifications.

If the pump carton is damaged, check contents immediately. Note damage on shipper's Bill of Lading and have shipper sign your statement. Notify the carrier immediately of the damage to arrange inspection of the pump and packaging.

The CARRIER ALONE is responsible for handling and settling your claim. Ritchie Engineering will cooperate in assessing damage if the pump is returned to the factory prepaid.

Carton contents include:

- SuperEvac pump
- Bottle of YELLOW JACKET SuperEvac Pump Oil
- Owner's manual
- Warranty registration card

To validate warranty, mail registration card within 10 days.

Warning:

- This unit generates a deep vacuum that can be harmful to human tissue. Do not expose any part of the human body to the vacuum.
- Do not operate this unit with the exhaust blocked or restricted. Remove red shipping cap prior to use.
- Keep unit a minimum of 4" (10 cm) from objects to provide adequate cooling of motor.
- Continuous sound pressure level of this unit can exceed 70dB (A).
- Wear goggles and protective clothing when using this product.

Features of your New Pump

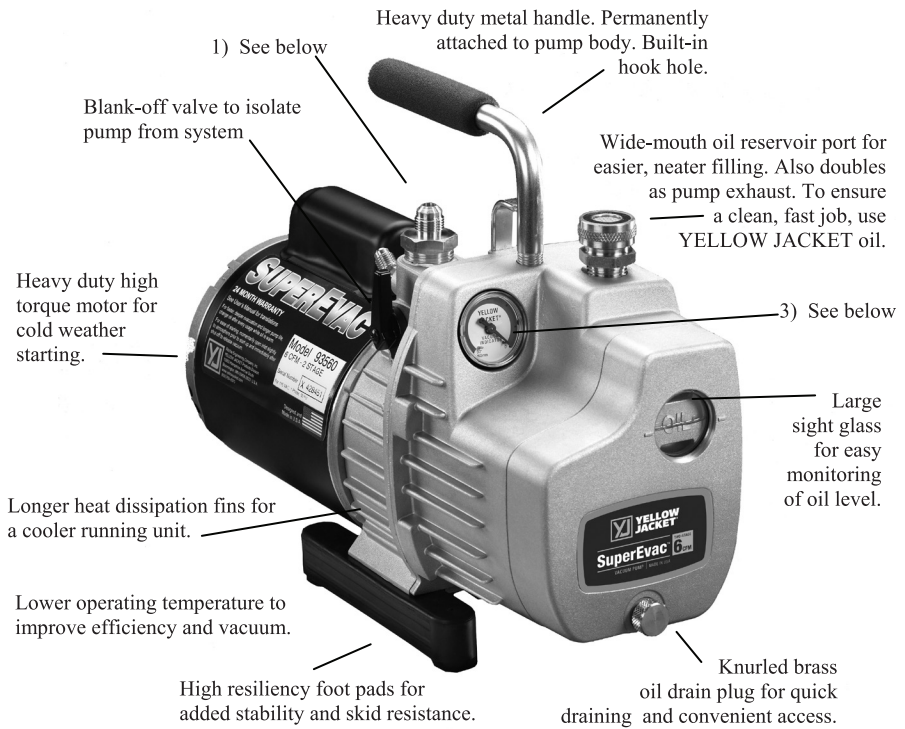

- 1) Male flare pump intake. Tethered cap stays with unit. Large diameter hose suggested for maximum pull down.
- 2) Additional 1/4" male flare port.
- 3) Vacuum gauge shows evacuation progress down to 30" range, so you'll know when to turn on electronic gauge for more precise reading.
- 4) Gas ballast valve (not shown) helps remove moisture and other condensable vapors that have been drawn into the pump as a result of evacuation.

Opening the ballast allows fresh air to enter the cartridge and keep vapors from combining with the oil. Vapors escape harmlessly through the exhaust valve. If combined with oil, vapors can turn the oil milky white and lower pump performance below specifications.

- 5) To operate ballast, turn the valve counter-clockwise one full turn after evacuation starts. As the vacuum reading reaches 1000-2000 microns, close the ballast to achieve a higher vacuum range.

The Purpose of the SuperEvac™ Design

The SuperEvac™ Pump is a 2-stage rotary vane design (at right) that increases efficiency and speeds pump down to 15 microns.

The pump lowers the internal pressure of a refrigeration system until moisture boils into a vapor. As the moisture is vaporized, it is evacuated by the pump, helping dehydrate the system. Most technicians try to achieve between 250 and 1000 microns.

A manometer or electronic vacuum gauge are the only ways to monitor evacuation progress. Manometer readings are approximate in inches of mercury. Only an electronic vacuum gauge (see page 8) is accurate enough to show when you reach the desired micron range.

As the chart shows, only an electronic vacuum gauge reads fine differences to provide assurance that the vacuum is low enough to boil the greatest possible amount of moisture.

Boiling temp of water	Inches mercury	Microns
212°F (100°C)	0	760,000
151°F (66°C)	22.05	200,000
101°F (38°C)	27.95	50,000
78°F (26°C)	28.95	25,000
35°F (2°C)	29.72	5,000
1°F (17°C)	29.882	1,000
- 50°F (-46°C)	29.919	50

How one small drop dampens your profits.

A small drop of moisture can hurt your profits and reputation.

During new system set-up, protective caps are removed admitting moisture and air into system components.

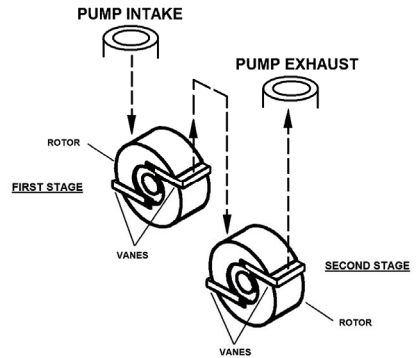

First stage exhausts into the intake of the second stage similar to two single stage pumps connected together.

If air – a non-condensable – remains in the system, it collects on the high side reducing system efficiency. This causes a rise in head pressure. The discharge valve gets hotter than normal and organic solids form causing compressor failure.

Moisture in the system can form ice which closes off openings in expansion valves and cap tubes, and prevent adequate cooling.

Ultimately moisture and air can produce acids and sludge which could cause in-warranty failures.

During service and parts replacement, the same contaminants get in again, and you could be called back for repairs by a dissatisfied customer.

Moisture and air can even enter through system leaks. And as the moisture in the air increases, so does the amount of contamination. The higher the humidity, the bigger your problem.

A vacuum pump "pulls" air and moisture out of the system before the system is damaged. The higher and more complete the vacuum, the more moisture is removed. That's why your SuperEvac pump is specifically engineered for high vacuums of 15 microns and better.

The 7 Important Steps of Initial Start-Up

- 1) Make sure motor is off and name plate voltage on motor bottom matches outlet voltage.
- 2) Remove oil fill cap on pump cover. Fill with YELLOW JACKET® SuperEvac™ Pump Oil until oil level is even with oil level line.
- 3) Make sure blank-off valve is in the open position (vertical). **Stay clear of the oil fill/exhaust port!** Remove intake cap to open intake to the atmosphere and then switch on the motor. When pump reaches running speed, replace cap. The vacuum indicator gauge should read 30 inches.
- 4) To check the pump's performance, attach a micron gauge to the 1/4" male flare fitting, making sure that the intake fitting is capped and the gas ballast valve is closed. Turn on the pump. The micron gauge will display the ultimate vacuum reached.
- 5) Improve cold weather starting by opening intake and running your pump for 10-15 seconds.
- 6) When turning pump off, open intake fitting until vacuum indicator gauge reads zero to break vacuum just prior to shut-off.
- 7) Disconnect pump and put cap on intake to keep out contaminants.
- 8) If an extension cord is needed, refer to the below chart for proper sizing:

RECOMMENDED EXTENSION CORD SIZES

Total Extension Cord Length (Feet)		
25'	50'	100'
16 Ga.	14 Ga.	12 Ga.
Wire Gauge (AWG)		

Vacuum Tips for Best Performance

Quick tips:

- 1) For the fastest vacuum, connect your pump **directly** to the system. Going through a manifold slows the job.
- 2) Use as **large** a hose as possible, even though the system has 1/4" fittings. A 1/2" or 3/8" hose allows a much faster and more complete vacuum.
- 3) Use as **short** a hose as practical to get maximum evacuation speed. Short hoses make evacuation faster than longer hoses. Long hoses slow the process.
- 4) **Metal hoses** are the most impervious so will be most effective in evacuation.
- 5) Evacuate through **both high and low** sides at the same time to speed evacuation.
- 6) Use the **4-in-1 Vacuum/Charge Valve & Core Tool (Part #18975)** to remove the Schrader valves from the system and evacuate through unrestricted lines for a faster and higher vacuum. Removing Schraders saves over 30% in time.
- 7) Use **two pumps** on very large systems to reduce vacuum time. Put one of the pumps on the low side of the system.



8) Use a **SuperEvac™ System I, II or III** to decrease vacuum time by over 50%. These systems include a 2-valve vacuum manifold and two 3/8" vacuum hoses which can evacuate three times faster than a 1/4" hose.



9) Use a heat gun on the condenser and evaporator to speed the evacuation process.

Built-in vacuum gauge:

The unique built-in indicator gauge in your pump monitors evacuation progress down to the 29-30" range. If the reading stays in the mid range, there is either high contamination or a large leak in the system.



Gross Leak

If you think there is excessive moisture, blow out the AC&R system with dry nitrogen wherever possible. This reduces the amount of contaminants that must be "pulled" into the pump and increases evacuation speed.

Use a nitrogen regulator valve with pressure limited to 150 psi, and a frangible disc device set at 175 PSIG.

When the indicator reaches the 29-30" range, turn on the electronic micron gauge for more precise readings.



Turn on electronic gauge

Oil changes

CHANGE OIL AFTER EACH USAGE to protect pump components from contaminants pulled into pump during service. Place used oil in a sealable container and dispose properly in accordance with local regulations.

YELLOW JACKET® vacuum pump oil is specially refined and formulated for extremely low vapor pressure and high pump efficiency at all temperature conditions. This means it can help you get a **continued return on your pump investment.**

In fact, with **proper maintenance**, your pump can keep making money for you up to ten years and more.

Proper maintenance includes -

1) Change the oil immediately after every use while the oil is still warm. This insures that contaminants are still in suspension and are removed with the oil.

If contaminants cool, solidify and stay in the pump, they lower vacuum efficiency. In extreme cases, the oil stops lubricating and the pump seizes.

Oil may look clean, but still be contaminated. "Looking clean" is not enough. One job is more than enough to contaminate oil. The only way to determine oil condition is to test vacuum pulled with an electronic vacuum gauge.

2) When finished with the pump, replace the tethered cap on the intake fittings (check for o-rings in caps). This keeps out moisture and contaminants.

SuperEvac vacuum levels can be reached only when the correct amount of **YELLOW JACKET** oil is used.

Use of other oils voids your pump warranty. Refrigerant oil, brake fluid and any other oil such as motor oil cannot be used.



Basic Troubleshooting

4 most common comments on pump return paperwork

1) **"Will not pump"** This usually means the pump will not pull a high enough vacuum. This can be caused by valve being left open, missing "O"-rings under caps or contaminated oil.

SUGGESTION: Change valve and "O"-rings change oil twice and recheck vacuum.

2) **"Will not pull below 1000 microns."**

SUGGESTION: Check for "O"-rings. Test pump to determine actual pull down. Remove all hoses and connect vacuum sensor directly to pump.

3) **"Noisy."** Pumps are noisy when they have not achieved a high vacuum. In intermediate vacuum, there will be oil, vane and exhaust noises.

SUGGESTION: Listen to the pump at high vacuum. If relatively quiet, the pump is running properly. If still noisy, there may be a system leak.

4) **"Repair and return."** This is the most difficult return comment to handle, since we are unsure of what needs to be done to keep the customer satisfied.

SUGGESTION: Be specific about the problem with your pump if returning it.

Starting problems

- Be sure pump is plugged into live receptacle with line voltage plus or minus 10% of voltage on motor nameplate. Long extension cords can greatly reduce voltage and cause problems.
- Pump/oil temp. must be 30°F (-1°C) or higher. Open intake to atmosphere and switch on pump; run up to speed before connecting to system.

- Your SuperEvac™ pump features a heavy-duty high torque motor for cold weather starting, but dirty oil makes starting more difficult, causing unnecessary wear on your unit.
- Dropping your pump can damage it. In a locked pump condition, motor will not run and the thermal overload will kick out.
- Disconnect power cord and set pump with front cover face down on table. Reach into coupling area and try to rotate the coupling. Do not use pliers. If the pump does not rotate, it is "locked up."

Oil leakage

- If leak develops between front and rear half of oil case, tighten all seven screws. Replace gasket if necessary.
- If shaft seal leaks, replace it.
- Wipe pump dry and watch for source of leak. Tighten screws and repair.

The steps to solving 95% of all problems

- 1) **Check oil level when pump is running.** It should be 1/2 to 5/8 up in the sight glass, the level necessary for proper operation.
- 2) **Check vacuum pump.** Connect micron gauge directly to the 1/4" port and cap intake port. Turn on pump, open the valve and check vacuum reading. If reading is good, check the system for leaks. OR, if testing a system, isolate pump with blank-off valve and get vacuum reading from the pump alone. If the pump does not pull and stay at a good vacuum level, run until hot and change oil.
- 3) **Check all flare connections.** Make sure they are tight.

SuperEvac™ LCD Digital Vacuum Gauge



This portable, lightweight, solid state instrument indicates the vacuum pressure in the system using thermocouple technology. This is important because you need to know the vacuum to confirm moisture removal. The battery powered gauge measures atmospheric pressures of 760,000 to 1 micron in easy to read 1/2" high numbers (**Part #69075**).

Diagnostics Chart

Condition	Pump Area	Possible Problem	Solution
Poor vacuum	Quiet pump	Dirty oil Drive coupling or set screw loose Bent or broken exhaust valve Pump not oiling Vaness not functioning	Flush 1 to 3 times Repair or replace Repair or replace Call factory Call factory
	Ultimate of pump - does not need mfg. spec (read with thermocouple)	Pump dropped Micron gauge malfunction Poor motor performance Dirty oil Air leaks System leaks Fitting sealant compound	Call factory Verify with second gauge Repair or replace Flush 1 to 3 times Repair or replace Isolate/repair Repair or replace
Oil Leaks	Exhaust	Oil level high System vented pressure through pump Pump tipped over	Adjust oil level Check oil level, add or replace oil Check oil level, add or replace oil
	Seal	Worn or damaged seal Motor loose	Replace Adjust/tighten, check seal
	Case	Gasket bolts loose Oil drain fitting Gasket damaged	Tighten Repair or replace Replace

Condition	Pump Area	Possible Problem	Solution
Pump won't start	Motor stalled hot/cold	Damaged motor Damaged pump Closed intake/gas ballast on pumps	Repair or replace Replace/call factory Open intake fitting and gas ballast.
	Thermal	Low voltage Cold weather cut-out Dirty oil	Shorter extension cord Open intake fitting for 10-15 sec. to warm up while starting. Flush 1 to 3 times
Unusually noisy	Motor areas	Worn motor Loose motor bolts Drive coupling	Replace motor Tighten bolts Adjust/replace coupling
	Pump cartridge	Dirt, low, improper oil Air leaks: 1) caps/connection 2) Gaskets/"O"-rings 3) Fittings 4) System leak	Flush and replace oil Tighten Replace/put on oil Replace/reseal Isolate pump with blank-off valve and repair system leak
High temp	Motor	Low voltage	Short extension cord
	Pump	Dirty oil Low oil Lint/foreign material Parts friction Too small for system Air leaks	Flush and replace Add/replace Open gas ballast Replace oil/call factory Size pump for system Replace/repair
Poor vacuum	Noisy pump	System leaks Low oil level Dirty oil Worn pump Air leaks and fittings or gasket seals	Repair leaks Add/replace Flush 1 to 3 times Replace module, call factory Replace/repair

Replacement Parts

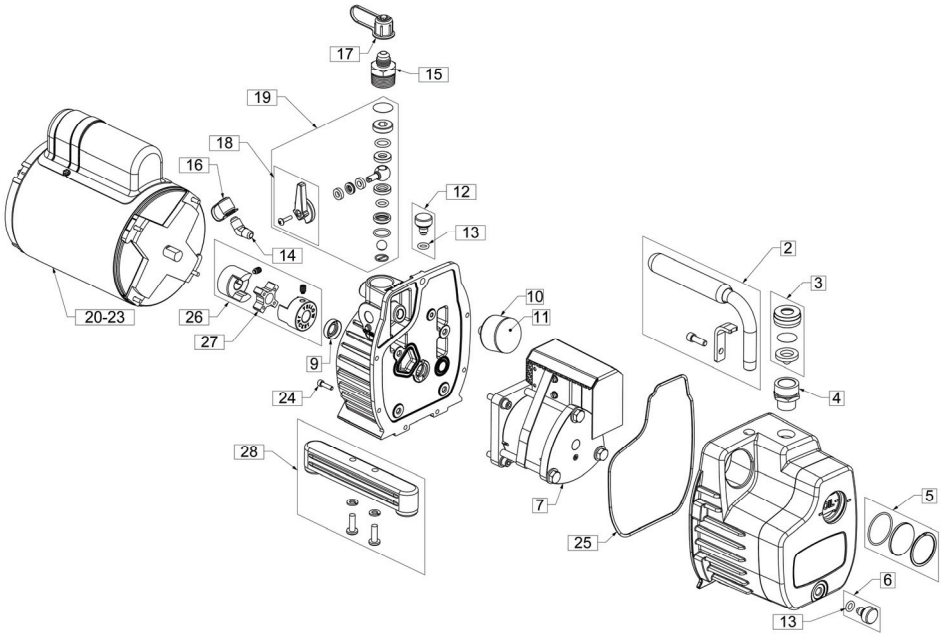

	Pump # 93514 93516 93594 9354x	Pump # 93515 93596 9356x	Pump # 93511 9358x	Pump # 93590 93592 93593 93595 93598
	4 CFM	6 CFM	8 CFM	11 CFM
	(95 L/M)	(142 L/M)	(190 L/M)	(260 L/M)
Pump oil cover				
1. Complete cover (individual parts listed below)	93501	93502	93503	93504
2. Handle with screw	93370	93370	93370	93370
3. Oil fill cap and seal	93390	93390	93390	93390
4. Oil fill fitting	93391	93391	93391	93391
5. Oil sight glass	93365	93365	93365	93365
6. Oil drain	93368	93368	93368	93368
Vacuum cartridge				
7. Complete cartridge with oil cover gasket	93541	93561	93581	93591

	Pump # 93514 93516 93594 9354x	Pump # 93515 93596 9356x	Pump # 93511 9358x	Pump # 93590 93592 93593 93595 93598
	4 CFM	6 CFM	8 CFM	11 CFM
	(95 L/M)	(95 L/M)	(95 L/M)	(260 L/M)
Mounting body				
8. Complete body (individual parts below)	93500	93500	93500	93500
9. Shaft seal	93031	93031	93031	93031
10. 30" vacuum gauge	93011	93011	93011	93011
11. Vacuum gauge crystal	93012	93012	93012	93012
12. Gas ballast with "O"-ring	93368	93368	93368	93368
13. "O"-ring for gas ballast/drain plug	93398	93398	93398	93398
14. 1/4" elbow fitting	93028	93028	93028	93028
15. Intake fittings	93377 (3/8") 40265 (Acme)	93377 (3/8") 40265 (Acme)	93393 (1/2") 40265 (Acme)	93393 (1/2") 40265 (Acme)
16. Intake cap (1/4")	93394	93394	93394	93394
17. Flare caps	93399 (3/8") 40284 (Acme)	93399 (3/8") 40284 (Acme)	93395 (1/2") 40284 (Acme)	93395 (1/2") 40284 (Acme)
18. Blank-off valve with handle	93366	93366	93366	93366
19. Complete parts for blank-off handle	93367	93367	93367	93367
Motor				
20a. 1/2 hp - 115V / 60 Hz (includes items 21, 22, 23a below)	93505	93505	93505	93505
20b. Export models: 1/2 hp - dual voltage 115V / 60 Hz, 230V / 50 Hz (includes items 21 and 22)	93513	93513	93513	93513
21. 8/32 x 7-1/4" motor bolts (4)	93099	93099	93099	93099
22. Rocker style switch	93117	93117	93117	93117
23a. 8' long US cord	93115	93115	93115	93115
23b. 8' long EU cord (detachable IEC-320)	95431	95431	95431	95431
23c. 8' long UK cord (detachable IEC-320)	95432	95432	95432	95432
Final assembly parts				
24. 8/32 x 5/8" socket head screws	93506	93506	93506	93506
25. Oil cover gasket	93507	93507	93507	93507
26. Drive coupling	93047	93047	93047	93047
27. Coupling spider	93050	93050	93050	93050
28. Right or left leg assembly with screws	93034	93034	93034	93034

Damaged supply cords must be replaced by special assemblies available from the manufacturer or its distributors.

9354x	9356x	9358x	9359x
28.3 lbs. (12.8 kg)	29.0 lbs. (13.1 kg)	30.3 lbs. (13.7 kg)	31.5 lbs. (14.3 kg)

WARRANTY INFORMATION

Ritchie Engineering guarantees YELLOW JACKET® products to be free of defective material and workmanship which could affect the life of the product when used for the purpose for which it was designed. This warranty does not cover items that have been altered, abused (including failure to use the correct type of vacuum pump oil) or returned solely in need of field service maintenance.

If found defective, we will either replace or repair at our option products within warranty period. Returns must be pre-paid.

Warranty does not cover use of lithium bromide, ammonia or leak stop type products.

See www.yellowjacket.com or contact customer service for full warranty details.

How to Obtain Service

Most returned pumps are merely in need of normal field service maintenance, such as changing oil or making minor adjustments. In many instances, the troubleshooting information in this manual can save you the time and effort of returning your pump. When the information contained in this manual, however, does not solve the problem, please call for service.

Call the Ritchie Engineering Customer Service Department:

Phone: (952) 943-1333 or
(800) 769-8370

Fax: (952) 943-1605 or
(833) 322-8684

E-mail: custserv@yellowjacket.com

You will receive personal help in determining if the problem can be solved without sending your pump to the factory and taking it out of service.



Ritchie Engineering Co., Inc.
YELLOW JACKET Products Division
10950 Hampshire Ave., S.
Bloomington, MN 55438-2623 USA
e-mail: custserv@yellowjacket.com
Web Site: www.yellowjacket.com

Phone: 800-769-8370
Int'l Phone: 952-943-1333
Fax: 800-322-8684
Int'l Fax: 952-943-1605