

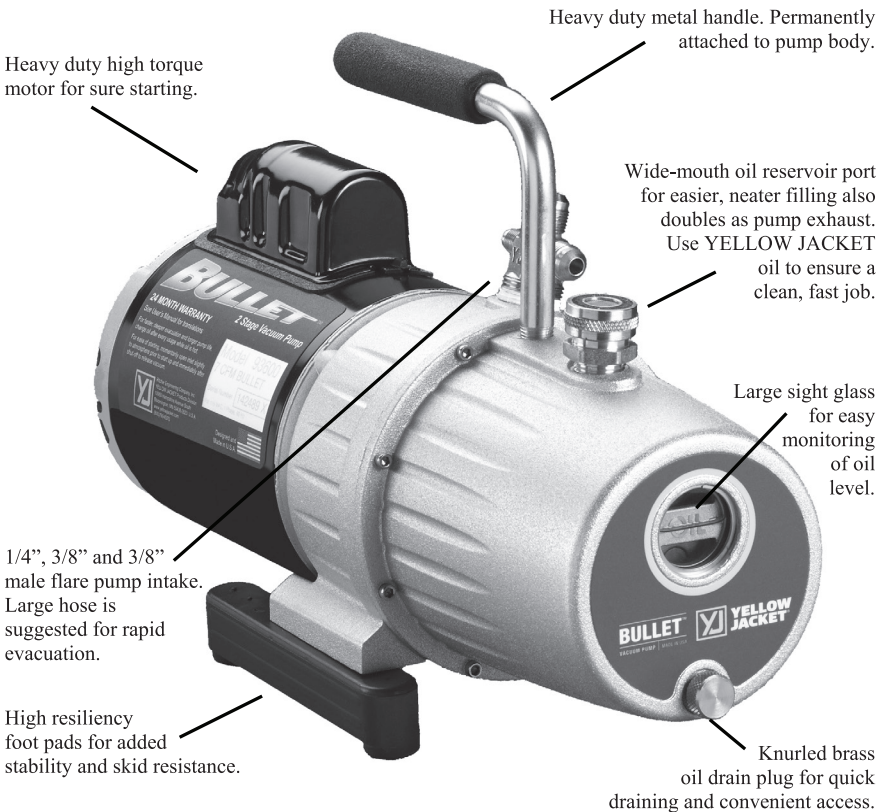

BULLET™



Operation and Maintenance Manual

Table of Contents

Page

The purpose of the BULLET™ design.....	3
The 7 important steps of initial start-up.....	4
Vacuum tips for best performance.....	4
Oil changes.....	5
Basic troubleshooting.....	6
• Starting problems	
• Oil leakage	
• The steps to solving 95% of all problems	
Diagnostic chart.....	7, 8
Replacement parts.....	9
Warranty and Service.....	10

Important Notices to Purchaser

Check for damage immediately. Prior to shipment, all YELLOW JACKET vacuum pumps are completely tested and inspected to assure compliance with Ritchie Engineering factory specifications.

The CARRIER ALONE is responsible for handling and settling your claim. Ritchie Engineering will cooperate in assessing damage if the pump is returned to the factory prepaid.

If the pump carton is damaged, check contents immediately. Note damage on shipper's Bill of Lading and have shipper sign your statement. Notify the carrier immediately of the damage to arrange inspection of the pump and packaging.

Carton contents include:

- BULLET™ vacuum pump
- Start-up bottle of YELLOW JACKET® SuperEvac™ Pump Oil
- Owner's manual
- Warranty registration card

To validate warranty, mail registration card within 10 days.

Warning:

- This unit generates a deep vacuum that can be harmful to human tissue. Do not expose any part of the human body to the vacuum.
- Do not operate this unit with the exhaust blocked or restricted. Remove red shipping cap prior to use.
- Keep unit a minimum of 4" (10 cm) from objects to provide adequate cooling of motor.
- Continuous sound pressure level of this unit can exceed 70dB (A).
- Always wear goggles and protective clothing when using this product.

The Purpose of the BULLET™ Design

The BULLET vacuum pump is a 2-stage rotary vane design (at right) that increases efficiency and evacuation speed.

The pump lowers the internal pressure of a refrigeration system until moisture boils into a vapor. As the moisture is vaporized, it is evacuated by the pump, helping dehydrate the system. Most technicians try to achieve between 250 and 1000 microns.

A manometer or electronic vacuum gauge are the only ways to monitor evacuation progress. Manometer readings are approximate in inches of mercury. Only an electronic vacuum gauge (see page 5) is accurate enough to show when you reach the desired micron range.

As the chart shows, only an electronic gauge reads fine differences to provide assurance that the vacuum is low enough to boil the greatest possible amount of moisture.

Boiling temp of water	Inches mercury	Microns
212°F (100°C)	0	760,000
151°F (66°C)	22.05	200,000
101°F (38°C)	27.95	50,000
78°F (26°C)	28.95	25,000
35°F (2°C)	29.72	5,000
1°F (17°C)	29.882	1,000
-50°F (-46°C)	29.919	50

How one small drop dampens your profits.

A small drop of moisture can hurt your profits and reputation.

During new system set-up, protective caps are removed admitting moisture and air into system components.

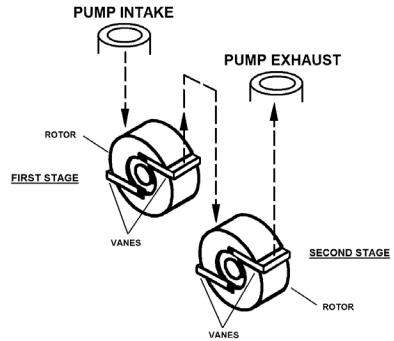

First stage exhausts into the intake of the second stage similar to two single stage pumps connected together.

If air – a non-condensable – remains in the system, it collects on the high side reducing system efficiency. This causes a rise in head pressure. The discharge valve gets hotter than normal and organic solids form causing compressor failure.

Moisture in the system can form ice which closes off openings in expansion valves and cap tubes, and prevent adequate cooling.

Ultimately moisture and air can produce acids and sludge which could cause in-warranty failures.

During service and parts replacement, the same contaminants get in again, and you could be called back for repairs by a dissatisfied customer.

Moisture and air can even enter through system leaks. And as the moisture in the air increases, so does the amount of contamination. The higher the humidity, the bigger your problem.

A vacuum pump "pulls" air and moisture out of the system before the system is damaged. The higher and more complete the vacuum, the more moisture is removed. That's why your BULLET vacuum pump is specifically engineered for high vacuums.

The 7 Important Steps of Initial Start-Up

- 1) Make sure motor is off and name plate voltage on motor bottom matches outlet voltage.
- 2) Remove oil fill cap on pump cover. Fill with YELLOW JACKET SuperEvac Pump Oil until oil level is even with oil level line.
- 3) Loosen intake cap to open intake to the atmosphere and then switch on the motor. When pump reaches running speed, replace cap. **Stay clear of the oil fill/exhaust port!**
- 4) To check the pump's performance, attach a micron gauge to the 1/4" male flare fitting, making sure that the intake is capped. Turn pump on. The micron gauge will display the ultimate vacuum reached.
- 5) Improve cold weather starting by opening intake and running your pump for 10-15 seconds.
- 6) When turning pump off, open intake fitting until vacuum is released.
- 7) Disconnect pump and put cap on intake to keep out contaminants.
- 8) If an extension cord is needed, use the chart below to determine the proper length:

RECOMMENDED EXTENSION CORD SIZES

Total Extension Cord Length (Feet)		
25'	50'	100'
16 Ga.	14 Ga.	12 Ga.
Wire Gauge (AWG)		

Vacuum Tips for Best Performance

- 1) For the fastest vacuum, connect your pump **directly** to the system. Going through a manifold slows the job.
- 2) Use as **large** a hose as possible, even though the system has 1/4" fittings. A 1/2" or 3/8" hose allows a much faster and more complete vacuum.
- 3) Use as **short** a hose as practical to get maximum evacuation speed. Short hoses make evacuation faster than longer hoses. Long hoses slow the process.
- 4) **Metal hoses** are the most impervious so will be the most effective in evacuation.
- 5) Evacuate through **both high and low** sides at the same time to speed evacuation.
- 6) Use the **4-in-1** Vacuum/Charge Valve and Core Tool to remove the Schrader valves from the system and evacuate through unrestricted lines for a faster and higher vacuum. Removing Schraders **saves over 30%** in time.
- 7) Use **two pumps** on very large systems to reduce vacuum time. Put one of the pumps on the low side of the system.
- 8) Use a **SuperEvac System I or II** to decrease vacuum time by over 50%. These systems include a 2-valve vacuum manifold and two 3/8" vacuum hoses which can evacuate three times faster than a 1/4" hose.
- 9) Use a heat gun on the condenser and evaporator to speed the evacuation process.

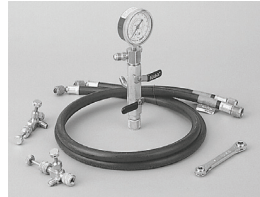

Part #18975

Oil Changes

CHANGE OIL AFTER EACH USAGE to protect pump components from contaminants pulled into pump during service. Place used oil in a sealable container and dispose of properly in accordance with local regulations.

YELLOW JACKET vacuum pump oil is specially refined and formulated for extremely low vapor pressure and high pump efficiency at all temperature conditions. This means it can help you get a **continued return on your pump investment**.

In fact, with **proper maintenance**, your pump can keep making money for you up to ten years and more.

Proper maintenance includes -

- 1) Change the oil immediately after every use while the oil is still warm. This insures that contaminants are still in suspension and are removed with the oil.

If contaminants cool, solidify and stay in the pump, they lower vacuum efficiency. In extreme cases, the oil stops lubricating and the pump seizes.

Oil may look clean, but still be contaminated. "Looking clean" is not enough. One job is more than enough to contaminate oil. The only way to determine oil condition is to test vacuum pulled with an electronic vacuum gauge.

- 2) When finished with the pump, replace the tethered cap on the intake fittings (check for o-rings in caps). This keeps out moisture and contaminants.

Vacuum levels can be reached only when the correct amount of YELLOW JACKET oil is used. **Use of other oils voids your pump warranty.** Refrigerant oil, brake fluid and any other oil such as motor oil cannot be used.



SuperEvac™ Digital Vacuum Gauge

This portable, lightweight, solid state instrument indicates the vacuum pressure in the system using thermocouple



technology. This is important because you need to know the vacuum to confirm moisture removal. The battery powered gauge measures atmospheric pressures of 760,000 to 1 micron in easy to read 1/2" high numbers (Part #69075).

Basic Troubleshooting

4 most common comments on pump return paperwork

1) **"Will not pump"** This usually means the pump will not pull a high enough vacuum. This can be caused by valve being left open, missing "O"-rings under caps or contaminated oil.

SUGGESTION: Change valve and "O"-rings, change oil twice and recheck vacuum.

2) **"Will not pull below 1000 microns."**

SUGGESTION: Check for "O"-rings. Test pump to determine actual pull down. Remove all hoses and adapters and connect vacuum sensor directly to the pump.

3) **"Noisy."** Pumps are noisy when they have not achieved a high vacuum. In intermediate vacuum, there will be oil, vane and exhaust noises.

SUGGESTION: Listen to the pump at high vacuum. If relatively quiet, the pump is running properly. If still noisy, there may be a system leak.

4) **"Repair and return."** This is the most difficult return comment to handle, since we are unsure of what needs to be done to keep the customer satisfied.

SUGGESTION: Be specific about the problem with your pump if returning it.

Starting problems

- Be sure pump is plugged into live receptacle with line voltage plus or minus 10% of voltage on motor nameplate. Long extension cords can greatly reduce voltage and cause problems.
- Pump/oil temp. must be 30°F (-1°C) or higher. Open intake to atmosphere and switch on pump; run up to speed before connecting to system.

- Your YELLOW JACKET vacuum pump features a heavy-duty high torque motor for cold weather starting, but dirty oil makes starting more difficult, causing unnecessary wear on your unit.
- Dropping your pump can damage it. In a locked pump condition, motor will not run and the thermal overload will kick out.
- Disconnect power cord, drain oil, and set pump with front cover face down on table. Reach into coupling area and try to rotate the coupling. Do not use pliers. If the pump does not rotate, it is "locked up."

Oil leakage

- If leak develops between front and rear half of oil case, tighten all eight screws. Replace gasket if necessary.
- If shaft seal leaks, replace it.
- Wipe pump dry and watch for source of leak. Tighten screws and repair.

The steps to solving 95% of all problems

- 1) **Check oil level when pump is running.** It should be 1/2 to 5/8 up in the sight glass, the level necessary for proper operation.
- 2) **Check vacuum pump.** Connect micron gauge directly to the 1/4" port and cap intake port. Turn on pump and check vacuum reading. If reading is good, check the system for leaks. OR, if testing a system, isolate pump with blank-off valve and get vacuum reading from the pump alone. If the pump does not pull and stay at a good vacuum level, run until hot and change oil.
- 3) **Check all flare connections.** Make sure they are tight with good seals.

Diagnostics Chart

Condition	Pump Area	Possible Problem	Solution
Poor vacuum	Quiet pump	Dirty oil Drive coupling or set screw loose Bent or broken exhaust valve Pump not oiling Vaness not functioning	Flush 1 to 3 times Repair or replace Repair or replace Call factory Call factory
	Ultimate of pump - does not meet mfg. spec (read with thermocouple)	Pump dropped Micron gauge malfunction Poor motor performance Dirty oil Air leaks System leaks Fitting sealant compound	Call factory Verify with second gauge Repair or replace Flush 1 to 3 times Repair or replace Isolate/repair Repair or replace
Oil Leaks	Exhaust	Oil level high System vented pressure through pump Pump tipped over	Adjust oil level Check oil level, add or replace oil Check oil level, add or replace oil
	Seal	Worn or damaged seal Motor loose	Replace Adjust/tighten, check seal
	Case	Gasket bolts loose Oil drain fitting Gasket damaged	Tighten Repair or replace Replace
Pump won't start	Motor stalled hot/cold	Damaged motor Damaged pump Closed intake	Repair or replace Replace/call factory Open intake fitting
	Thermal	Low voltage Cold weather cut-out Dirty oil	Shorter extension cord Open intake fitting for 10 - 15 seconds to warm up while starting Flush 1 to 3 times
Poor vacuum	Noisy pump	System leaks Low oil level Dirty oil Worn pump Air leaks and fittings or gasket seals	Repair leaks Add/replace Flush 1 to 3 times Replace cartridge Replace/repair

Continued on next page...

Diagnostics Chart, cont.

Condition	Pump Area	Possible Problem	Solution
Unusually noisy	Motor areas	Worn motor Loose motor bolts Drive coupling	Replace motor Tighten bolts Adjust/replace coupling
	Pump cartridge	Dirt, low, improper oil Air leaks: 1) caps/connection 2) Gaskets/"O"-rings 3) Fittings 4) System leak	Flush and replace oil Tighten Replace/put on oil Replace/reseal Isolate pump with blank-off valve and repair system leak
High temp	Motor	Low voltage	Short extension cord
	Pump	Dirty oil Low oil Parts friction Too small for system Air leaks	Flush and replace Add/replace Replace oil/call factory Size pump for system Replace/repair

Replacement Parts

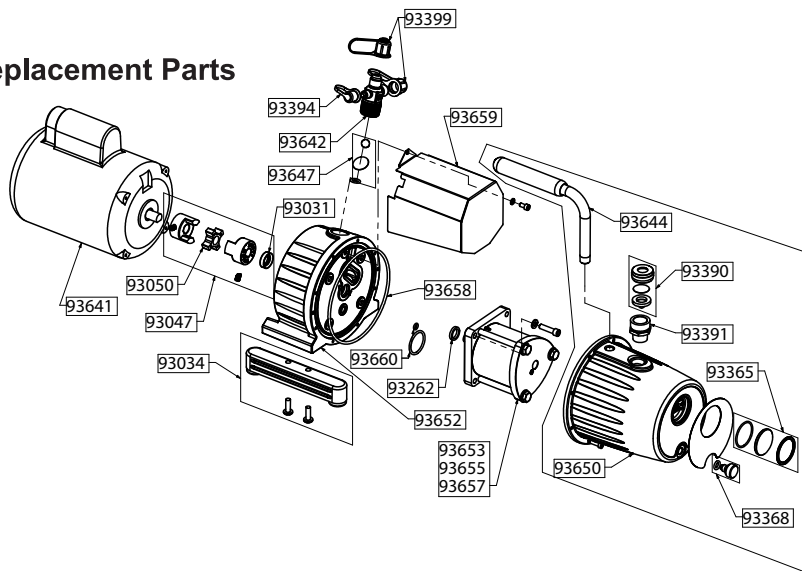

Part #	Description	Part #	Description
93031	Shaft seal	93513	1/2 hp motor - dual voltage 115V/60 Hz, 230V/50 Hz
93034	Universal pump leg (1)	93394	1/4" flare cap and strap
93047	Drive Coupling	93399	3/8" flare cap and strap
93050	Coupling spider for 93047	93641	1/2 hp motor - 115V/60 Hz
93115*	8' long US cord	93642	3/8", 3/8" and 1/4" male flare intake fitting
93262	Cartridge ring	93644	BULLET pump handle
93365	Sight glass	93647	BULLET anti-suckback assembly
93368	Oil drain	95431*	8' long EU cord (detachable IEC-320)
93390	Oil fill cap	95432*	8' long UK cord (detachable IEC-320)
93391	Oil fill fitting		
Built 2010 - 2013		Built 2014 -	
93633	3 CFM (85 L/M) complete cartridge with intake gaskets	93653	3 CFM (85 L/M) complete cartridge with intake gaskets
93635	5 CFM (142 L/M) complete cartridge with intake gaskets	93655	5 CFM (142 L/M) complete cartridge with intake gaskets
93637	7 CFM (200 L/M) complete cartridge with intake gaskets	93657	7 CFM (200 L/M) complete cartridge with intake gaskets
93643	BULLET pump cover gasket	93658	BULLET pump cover gasket
93646	BULLET cartridge baffle	93659	BULLET cartridge baffle
93648	BULLET cartridge gaskets	93660	BULLET cartridge gaskets
93649	BULLET pump cover assembly	93650	BULLET pump cover assembly
93651	Complete mounting body	93652	Complete BULLET mounting body

*Damaged supply cords must be replaced by special assemblies available from the manufacturer or its distributors.

WARRANTY INFORMATION

Ritchie Engineering guarantees YELLOW JACKET products to be free of defective material and workmanship which could affect the life of the product when used for the purpose for which it was designed. This warranty does not cover items that have been altered, abused (including failure to use the correct type of vacuum pump oil) or returned solely in need of field service maintenance.

If found defective, we will either replace or repair at our option products within warranty period. Returns must be prepaid.

Warranty does not cover use of lithium bromide, ammonia or leak stop type products.

See www.yellowjacket.com or contact customer service for full warranty details.

How to Obtain Service

Most returned pumps are merely in need of normal field service maintenance, such as changing oil or making minor adjustments. In many instances, the troubleshooting information in this manual can save you the time and effort of returning your pump. When the information contained in this manual, however, does not solve the problem, please call for service.

Call the Ritchie Engineering Customer Service Department:

Phone: (952) 943-1333 or
(800) 769-8370

Fax: (952) 943-1605 or
(833) 322-8684

E-mail: custserv@yellowjacket.com

You will receive personal help in determining if the problem can be solved without sending your pump to the factory and taking it out of service.



Ritchie Engineering Co., Inc.
YELLOW JACKET Products Division
10950 Hampshire Ave., S.
Bloomington, MN 55438-2623 USA
e-mail: custserv@yellowjacket.com
Web Site: www.yellowjacket.com

Phone: 800-769-8370
Int'l Phone: 952-943-1333
Fax: 800-322-8684
Int'l Fax: 952-943-1605