

DEFROST DIFFERENTIAL PRESSURE REGULATING VALVES

for Supermarket Systems

DDR-20

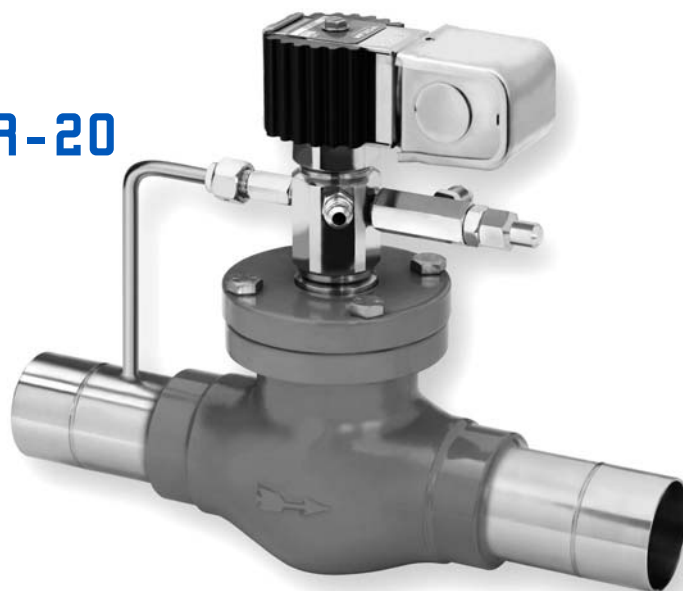

OLDR-15

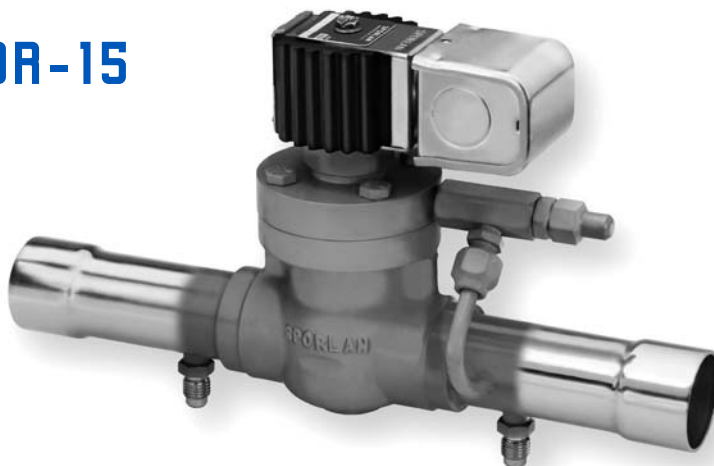

SPORLAN DEFROST DIFFERENTIAL PRESSURE REGULATING VALVES OFFER THESE BENEFITS:

- Able to maintain a differential pressure between the defrost header and the liquid header, allowing reverse flow during the defrost cycle.
- Combines a liquid differential valve and a solenoid valve into one component, thus reducing piping costs.
- Ability to adjust the differential setting from 5 to 50 psid.

In many supermarket applications refrigerant gas from the discharge line, or from the top of the receiver, is used for defrost. This method of defrost diverts a portion of the hot gas or cool gas (from the top of the receiver) to the suction line, and back through the evaporator being defrosted. The gas condenses in the evaporator and flows in reverse, through a check valve, around the TEV and liquid line solenoid valve. Liquid refrigerant then flows to the liquid header where it is distributed to evaporators not in the defrost cycle. In order for reverse flow to occur, the pressure of the defrost header must be greater than the pressure of the liquid header. The difference in pressure is known as the defrost differential.

Several methods are used to obtain the defrost differential. A common **liquid line method** is to install a differential check valve in parallel with a solenoid valve between the receiver and the liquid header. When the solenoid valve is closed during defrost, it allows the differential check valve to control the receiver at a greater pressure than the liquid header. Sporlan offers the (O)LDR-15, (O)LDR-20, XTM and XTO versions for this application. The (O)LDR, XTM or XTO valves combine the features of the liquid differential check valve and the solenoid valve into a single component.

A **discharge line method** is to install a discharge differential pressure regulating valve in the discharge line before the condenser. In order for the reverse flow of hot gas to occur, the pressure of the discharge gas (defrost header) must be greater than the pressure of the receiver (liquid header). Sporlan offers the DDR-20 for this application. A solenoid feature allows the valve to control the differential when the coil is de-energized and to operate full open when the coil is energized.

OPERATION

(O)LDR, XTM AND XTO VALVE DESIGN & OPERATION

The (O)LDR is designed to maintain a differential pressure between the receiver and the liquid header. A pilot differential valve controls the (O)LDR by varying the pressure on top of the main piston. These valves are available in two port sizes, the (O)LDR-15 (1") and the (O)LDR-20 (1-5/16"). Inlet pressure enters the

pilot assembly through a passageway in the valve body on the (O)LDR-15, and through an external tube connected to the inlet fitting on the (O)LDR-20. The outlet on the pilot differential valve is connected to the outlet fitting with an external tube on both valves.

Sporlan liquid line differential valves have a solenoid bypass feature that allows the valve to remain full open or modulate to maintain a differential. We supply two versions of liquid line differential valves:

The **OLDR** is in the **full open position** when the coil is de-energized (Figure 3), and it is in the differential operation mode when the coil is energized (Figure 1). The OLDR uses the MKC-2 coil. Refer to Bulletin 30-10 for more information on Sporlan solenoid coils.

The **LDR** is in the **differential operation mode** when the coil is de-energized (Figure 2), and it is in the full open position when the coil is energized (Figure 4). The LDR uses the OMKC-2 coil. Refer to Bulletin 30-10 for more information on Sporlan solenoid coils.

The **XTM** operates identically to the LDR-15 and the **XTO** operates identically to the LDR-20. The special feature of the XTM and XTO versions are the unique outlet fitting configurations. Different outlet fittings are indicated by a suffix -1, -4, or -5 (i.e. the XTM-1 has connections 1-3/8" ODF x 1-3/8" ODF 90° elbow). For piping considerations, if replacement is necessary, an exact replacement is best. The internal parts are interchangeable between the LDR-15 and the XTM, and between the LDR-20 and XTO. Refer to the Specification table on page 8 for further details, and Bulletin 90-51 for service and installation instructions.

(O)LDR, XTM AND XTO DIFFERENTIAL OPERATION

OLDR - Coil Energized

LDR, XTM and XTO - Coil De-energized

The plunger lifts off the pilot port, allowing inlet pressure to enter the chamber on top of the main piston. It then bleeds out through the pilot differential valve (See Figures 1 and 2). When the differential pressure across the valve is below the setting of the pilot differential valve, the pilot differential valve modulates closed. Closing the pilot differential valve allows pressure to build on top of the main piston. As this

FOR USE ON REFRIGERATION and/or AIR CONDITIONING SYSTEMS ONLY

Bulletin 90-50, April 2004, supersedes Bulletin 90-50, dated May 1999, and all prior publications.

© Copyright 2004 By Sporlan Valve Company, Washington, MO 63090

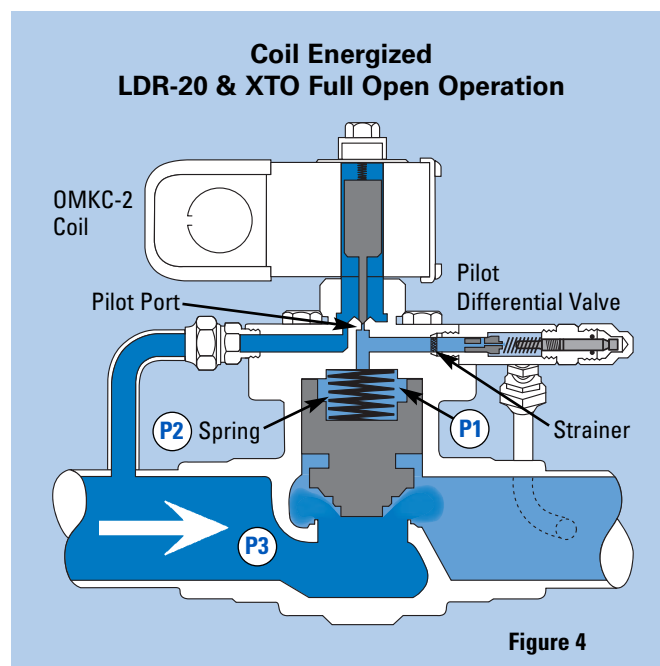
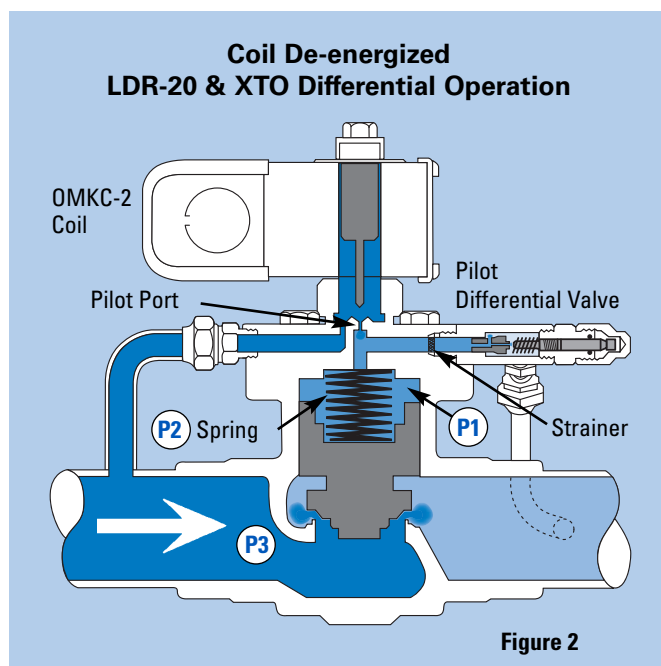
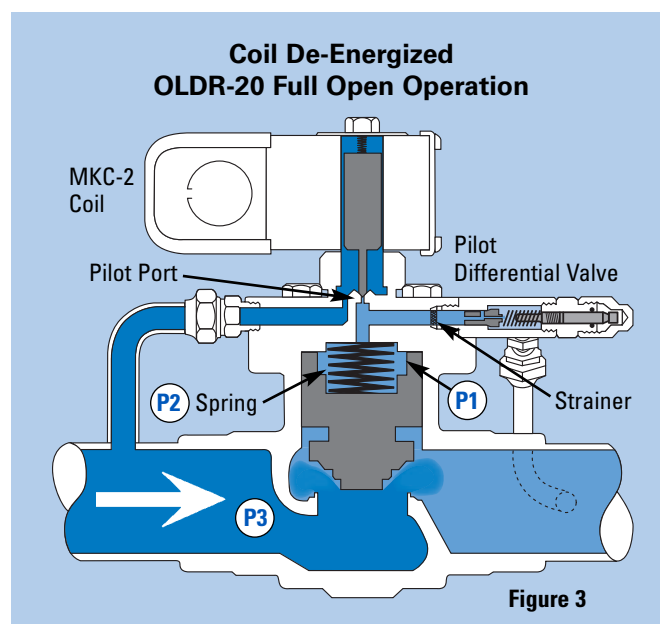
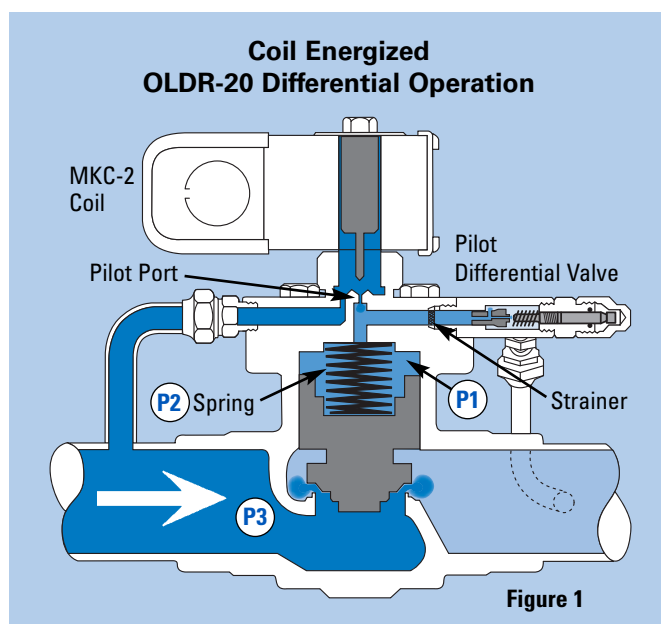

pressure (P1) approaches the inlet pressure (P3), the force, combined with the force from the spring (P2), pushes the piston down, modulating the valve in the closing direction.

As the differential pressure rises above the pilot differential valve setting, the pilot differential valve modulates open. This bleeds refrigerant from the chamber on top of the piston at a faster rate than refrigerant is entering, so the pressure (P1) decreases. As this pressure (P1) plus the pressure from the spring (P2) falls below the inlet pressure (P3), the inlet pressure pushes the piston up, modulating the valve open. The valve will open only as far as necessary to maintain the pilot differential valve setting. The pilot differential valve will then modulate the piston from partially open to partially closed to maintain the valve setting.

(O)LDR, XTM AND XTO FULL OPEN OPERATION

**OLDR - Coil De-energized
LDR, XTM and XTO - Coil Energized**

The plunger moves down to close the pilot port, stopping all flow to the chamber above the piston. The refrigerant remaining above the piston then bleeds to the valve outlet through an orifice (bleed hole) in the pilot differential valve piston. The pressure in the chamber (P1) decreases so the inlet pressure (P3) moves the piston up and the valve opens (See Figures 3 and 4).

DDR-20 VALVE DESIGN AND OPERATION

The DDR-20 is designed to create a differential pressure between its inlet (discharge) pressure and the receiver pressure. The pilot differential valve controls the DDR-20 by varying the pressure on top of the main piston. The pilot differential valve senses receiver

pressure through a field installed pilot line connecting the pilot differential valve to the receiver. Inlet pressure enters the pilot assembly through an external tube. This inlet pressure bleeds through a fixed restrictor to the top of the main valve piston. Pressure on top of the main piston is bled off through the pilot differential valve.

A solenoid bypass feature is incorporated in the valve so that the valve will modulate fully open when there is no need to create a differential. Energizing the solenoid coil opens the valve fully. The DDR-20 uses the MKC-2 coil. Refer to Bulletin 30-10 for more information on Sporlan solenoid coils.

DDR-20 DIFFERENTIAL OPERATION

Coil De-energized

The kick-off spring forces the pin and plunger down, closing Port A and opening Port B. Discharge gas enters the chamber on top of the piston through Port B, and is bled out through the pilot differential valve, to the receiver (See Figure 5).

When the differential pressure between the discharge line and the receiver is below the setting of the pilot differential valve, the pilot differential valve modulates closed. Closing the valve allows pressure to build on top of the main piston. As this pressure (P1) approaches the inlet pressure (P3), the force, combined with the force from the spring (P2), pushes the piston down, modulating the valve closed.

As the differential pressure rises above the pilot differential valve setting, the pilot differential valve modulates open. The open pilot differential valve bleeds

refrigerant from the chamber on top of the piston at a faster rate than refrigerant is entering, therefore the pressure decreases. As this pressure (P1) plus the pressure from the spring (P2) falls below the inlet pressure (P3), the inlet pressure pushes the piston up, modulating the valve open. The valve opens only as far as necessary to maintain the pilot differential valve setting. The pilot differential valve then modulates the piston from partially open to partially closed to maintain the valve setting.

DDR-20 FULL OPEN OPERATION

Coil Energized

Energizing the solenoid pulls the pin and plunger up, opening Port A. The discharge gas entering the pilot assembly then forces the small ball up to close Port B (See Figure 6).

When Port B is closed, discharge gas can no longer enter the chamber on top of the main piston. The pilot differential valve closes, and refrigerant from the top of the piston bleeds to the suction line through Port A and Fitting C. This decreases pressure in the chamber (P1), so the inlet pressure (P3) moves the piston up and the valve opens.

APPLICATION

Defrost Differential Pressure Regulating Valves are used on supermarket systems to allow reverse flow of refrigerant gas through the suction line and evaporator during a defrost. The valves accomplish this by maintaining the defrost header at a greater pressure than the liquid header. Correct application depends

Figure 5 Coil De-Energized Differential Operation

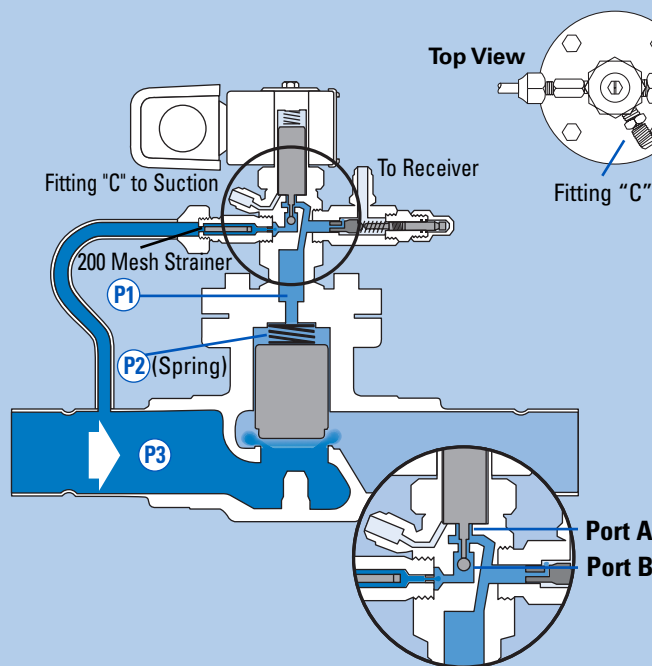
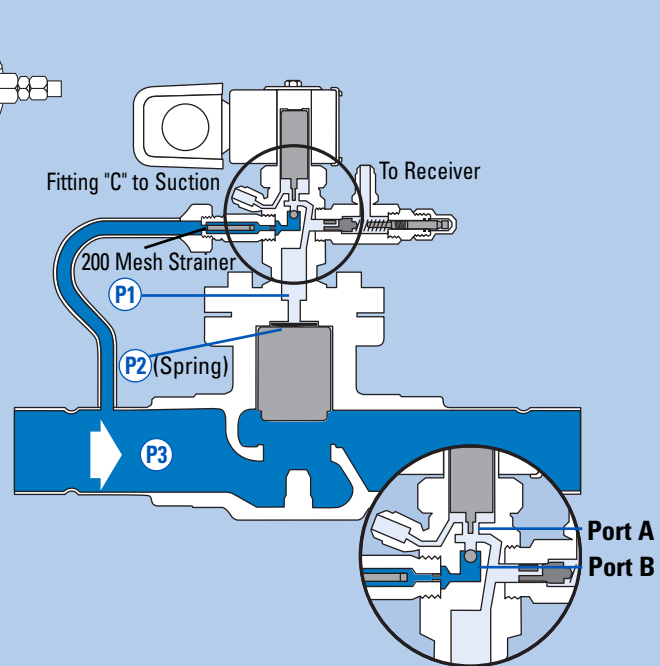

Figure 6 Coil Energized Full Open Operation



on several factors. Either of the two types of defrost differential pressure regulating valves (liquid line or discharge line) can be applied on supermarket systems. However, the two types cannot be applied on the same system.

LOCATION AND PIPING

The (O)LDR, XTM and XTO valves are located between the receiver and the liquid header (See Figure 8). The DDR-20 is located in the discharge line before the condenser (See Figure 7). The two types of defrost differential valves (liquid line and discharge line) cannot be applied on the same system. Sporlan recommends consulting recognized piping references for assistance in piping procedures. Sporlan is not responsible for system design, any damage arising from faulty system design, or for misapplication of its products. If these valves are applied in any manner other than as described in this bulletin or other Sporlan literature, the Sporlan warranty is void.

IMPORTANT: There are two pilot lines from the DDR-20 that **must** be installed in the field for the valve to operate properly. The 1/4 SAE fitting on the pilot dif-

ferential valve must be connected to the receiver. The second 1/4 SAE fitting, located below the solenoid coil (Fitting C), must be connected to the suction line. The pilot line to suction is not a constant high to low side bleed. It only bleeds the small amount of refrigerant from the top of the valve's main piston to open the valve when the solenoid coil is energized. Once the valve is open, and at all other times, there is no high to low side bleed. When the valve is modulating, the bleed through the pilot differential valve is to the receiver.

ADJUSTMENT RANGE AND PRESSURE SETTINGS

All defrost differential valves are set by turning the adjusting stem located under the cap on the pilot differential valve. The adjustment range is 5 to 50 psig. The (O)LDR, XTM and XTO have a factory setting of 18 psid, and the DDR-20 has a factory setting of 30 psid. Turning the stem clockwise increases the setting, counterclockwise decreases the setting. Adjustments must be made with the valve in its differential mode and no refrigerated cases in defrost, so that the head pressure is normal. Complete instructions on setting the valves are given in Bulletin 90-51.

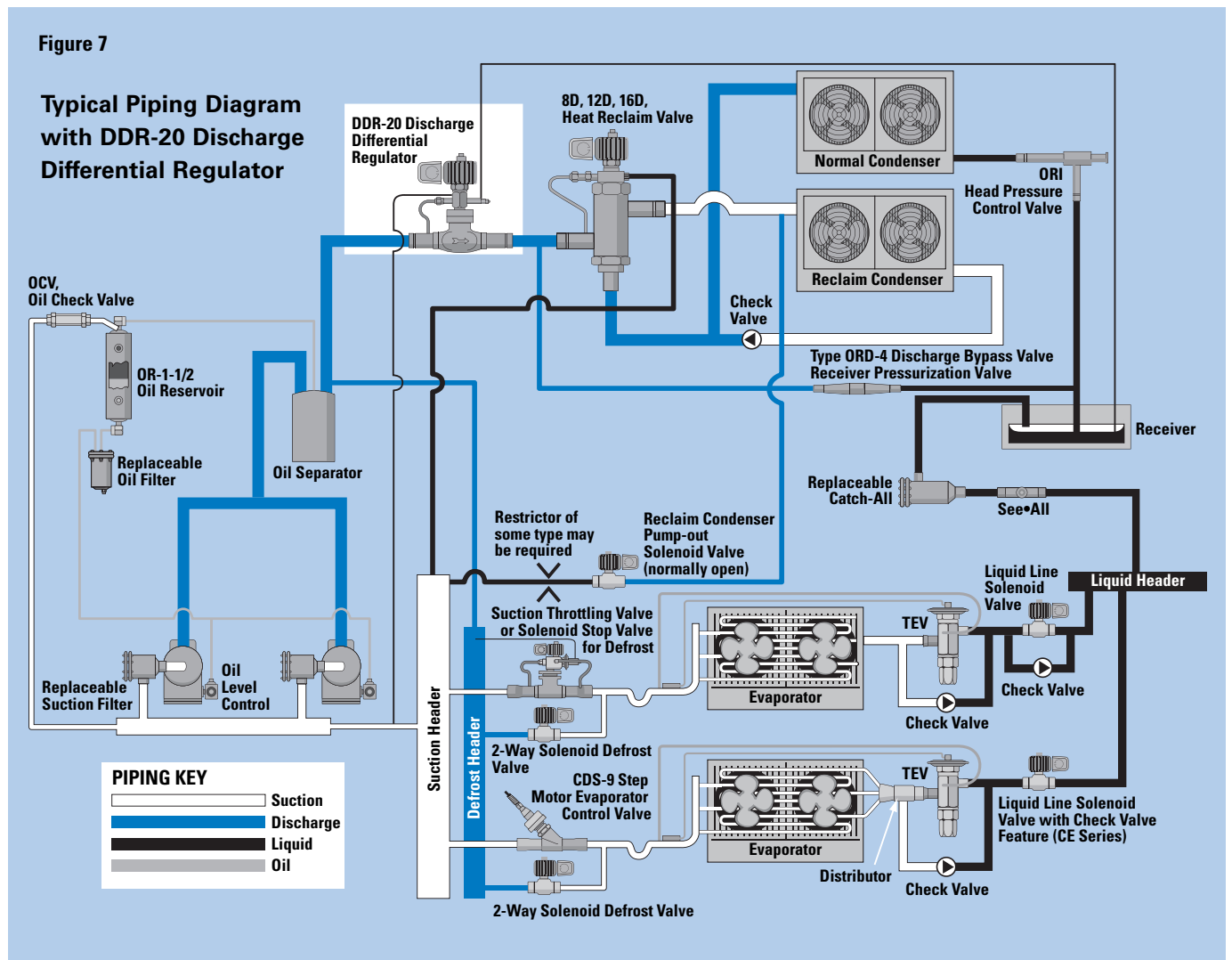
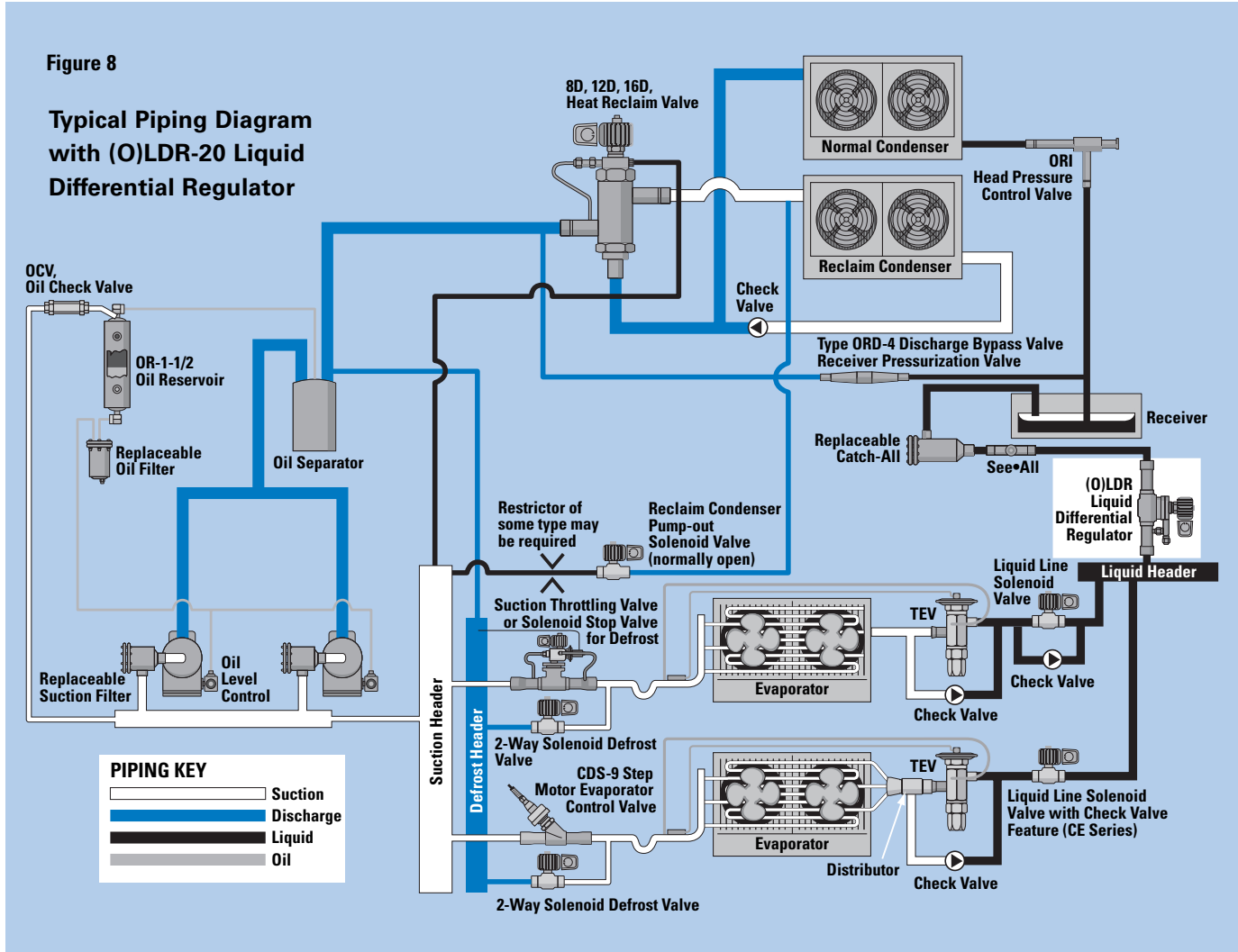

Figure 8

Typical Piping Diagram with (O)LDR-20 Liquid Differential Regulator



SELECTION

Selection involves five basic system criteria:

1. Refrigerant
2. The type of Defrost Differential Valve (*Liquid Differential Pressure Regulating Valve or Discharge Differential Pressure Regulating Valve*)
3. Allowable design pressure drop across the valve
4. Liquid temperature
5. Common suction temperature

A normally open OLDR version or an LDR version (differential mode when the coil is de-energized) must be determined if a liquid differential pressure regulating valve is desired.

Example:

Select a Liquid Defrost Differential Pressure Regulating Valve for a 40 ton R-22 supermarket system with a liquid temperature of 90°F and a common suction temperature of 0°F.

From the capacity table on page 7, the (O)LDR-15 has a capacity of 46.9 tons at a 2 psi pressure drop. The correction factor for 90°F liquid is 1.06, and the correction factor for 0°F suction is 0.91.

Therefore 46.9 tons multiplied by 1.06 and 0.91 is equal to 45.2 tons. The OLDR-15-5/50 is the appropriate selection.

Example:

Select a Discharge Differential Pressure Regulating Valve for a 20 ton R-404A supermarket system with a liquid temperature of 60°F and a common suction of -20°F.

From the capacity table on page 7, the DDR-20 has a capacity of 18.7 tons at a 2 psi pressure drop. The correction factor for 60°F liquid is 1.43 and the correction factor for -20°F suction is 0.85.

Therefore 18.7 tons multiplied by 1.43 and 0.85 is equal to 22.7 tons. The DDR-20-5/50 is the appropriate selection.

CAPACITIES - TONS OF REFRIGERATION																	
REFRIGERANT																	
22						134a						404A/507					
PRESSURE DROP ACROSS VALVE - psi																	
.5	1	2	3	4	5	.5	1	2	3	4	5	.5	1	2	3	4	5
TYPES LDR-15, OLDR-15 & XTM																	
-	33.2	46.9	57.6	66.5	74.3	-	31.0	43.9	53.8	61.2	69.5	-	22.0	31.1	38.1	44.0	49.2
TYPES LDR-20, OLDR-20 & XTO																	
-	73.4	104	127	147	164	-	68.7	97.1	119	136	154	-	48.6	68.7	84.2	97.3	109
TYPE DDR-20																	
10.3	14.6	20.6	25.1	29.0	32.3	8.57	12.1	17.0	20.8	24.0	26.6	9.35	13.2	18.7	22.8	26.3	29.3

Capacities are based on 40°F evaporator temperature, 100°F condenser temperature, 25°F superheated return gas, discharge gas temperature 50°F above isentropic compression. For capacities at other liquid or evaporator temperatures use multipliers in table below:

LIQUID TEMPERATURE CORRECTION FACTORS																
REFRIGERANT LIQUID TEMPERATURE °F		0	10	20	30	40	50	60	70	80	90	100	110	120	130	140
REFRIGERANT	22	1.56	1.51	1.45	1.40	1.34	1.29	1.23	1.17	1.12	1.06	1.00	0.94	0.88	0.82	0.76
	134	1.70	1.63	1.56	1.49	1.42	1.36	1.29	1.21	1.14	1.07	1.00	0.93	0.85	0.78	0.71
	404A	2.04	1.94	1.84	1.74	1.64	1.54	1.43	1.33	1.22	1.11	1.00	0.89	0.77	0.65	0.53

EVAPORATOR TEMPERATURE CORRECTION FACTORS									
EVAPORATOR TEMPERATURE °F	-40	-30	-20	-10	0	10	20	30	40
Multiplier	0.80	0.83	0.85	0.88	0.91	0.93	0.95	0.98	1.00

DESIGNATION / ORDERING INSTRUCTIONS

Select from the capacity table above. When ordering be sure to give complete valve designation including voltage and cycles.

OLDR

O	LDR	-	15	-	5/50	-	1-3/8 ODF	-	120/50-60
Normally Open	Liquid Differential Regulator		Valve Size		Adjustment Range - psi		Connections - Inches		Electrical Specifications

DDR

DDR	-	20	-	5/50	-	1-5/8 ODF	-	120/50-60
Discharge Differential Regulator		Valve Size		Adjustment Range - psi		Connections - Inches		Electrical Specifications

SPECIFICATIONS

VALVE TYPE	PORT SIZE Inches	DIFFERENTIAL SETPOINT RANGE	CONNECTIONS - Inches INLET x OUTLET	DIMENSIONS - Inches				COIL	WEIGHT - lbs*	
				A	B	C	D		Net	Shipping
OLDR-15	1	5/50 psi	1-1/8 ODF x 1-1/8 ODF	10.06	1.63	5.00	2.62	MKC-2	4	5
LDR-15			or	10.06	1.63	5.56	2.62	OMKC-2	4	5
OLDR-20	1-5/16		1-3/8 ODF x 1-3/8 ODF	11.06	1.77	5.56	3.34	MKC-2	9	10.5
LDR-20			or	11.06	1.77	6.12	3.34	OMKC-2	9	10.5
XTM-1	1		1-3/8 ODF x 1-3/8 ODF, 90° Elbow	9.22	1.63	5.56	2.62	OMKC-2	4	5
XTM-5			1-1/8 ODF x 1-3/8 ODF, 90° Elbow	9.22	1.63	5.56	2.62		4	5
XTO-1	1-5/16		1-5/8 ODF x 1-5/8 ODF, 90° Elbow	10.38	1.77	6.12	3.34		9	10.5
XTO-4			2-1/8 ODF x 2-1/8 ODF	11.06	1.77	6.12	3.34		9	10.5
DDR-20	1-5/16	1-5/8 ODF x 1-5/8 ODF	See drawing below				MKC-2	9.5	10.5	

* Add 1 pound for solenoid coil.

The XTM-1, XTM-5, XTO-1 and XTO-4 are Underwriters Laboratories Listed under Guide No. Y10Z, File No. MH4576. Maximum Rated Pressure of 400 psig. MOPD of 300 psig.

OLDR-15

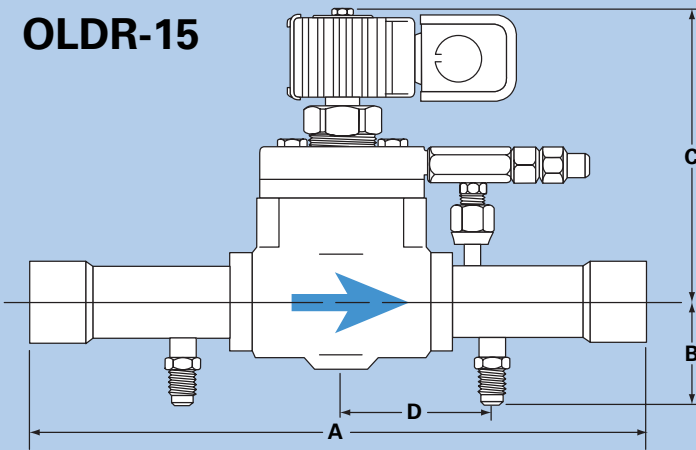

XTM

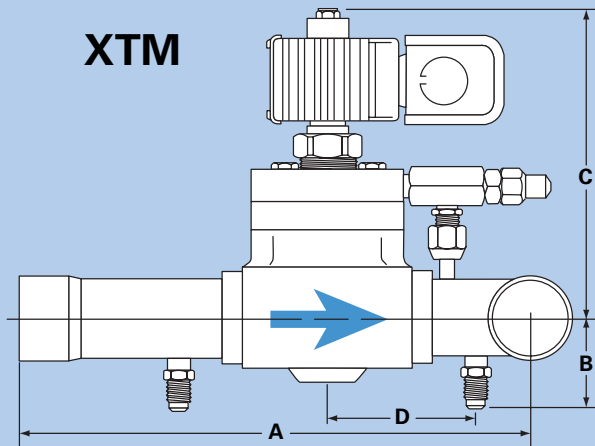

NOTE: (O) LDR-15 size valves do not have the tube from inlet fitting to pilot assembly. Inlet pressure enters the pilot assembly through a passageway in the valve body.

DDR-20

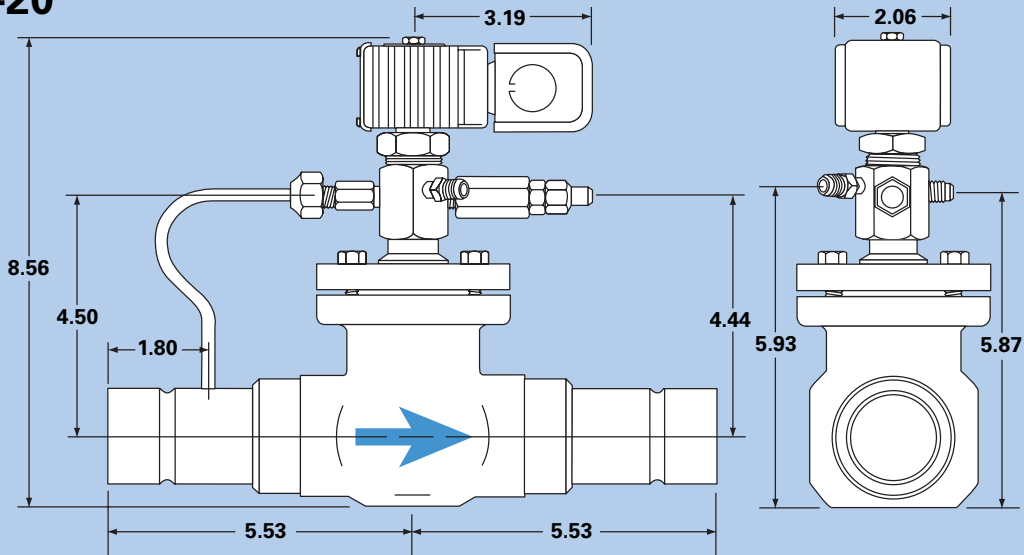

SPORLAN VALVE COMPANY



206 LANGE DRIVE • WASHINGTON, MO 63090
636-239-1111 • FAX 636-239-9130