



Suction Line Accumulators

Design

The function of a suction line accumulator in a heat pump or refrigeration system is to catch and hold any unused portion of the system charge. The device must also prevent liquid slugging of the compressor and excessive refrigerant dilution of the compressor oil.

The accumulator must return refrigerant and oil to the compressor at a sufficient rate to maintain both system operating efficiency and proper crankcase oil level. To make sure these tasks are accomplished, system designers must consider the following items:

- The accumulator must have sufficient internal volume.
- A properly sized and protected oil return orifice is required to ensure positive oil (and refrigerant) return to the compressor.
- The pressure drop across the accumulator should be as low as possible.

Oil return at a minimum flow rate is controlled by the outlet U-tube size. Refrigerant and oil will be returned to the compressor by pressure drop across the orifice metering area and the liquid head above the orifice. Other design requirements include safe working pressure, agency approvals and corrosion resistance.

Figure 1 illustrates a typical accumulator with an inlet deflector. The shape of the deflector directs the inlet flow in a slightly downward tangential direction.

The inlet to the U-tube is located behind the inlet deflector to prevent liquid carry-over and is bell-shaped to reduce the sudden contraction loss of the high-velocity gas. The U-tube diameter is selected to minimize pressure drop at high flow rates yet provide adequate oil return at low flow rates.

Other features include a 50 x 60 mesh screen to protect the oil return orifice, an anti-siphon hole and a fusible alloy plug in the accumulator. The anti-siphon hole located near the outlet of the U-tube prevents liquid from siphoning into the outlet tube and compressor during an off-cycle. The fusible alloy plug is generally a U.L. requirement since it is a safety device to protect against excessive pressure in the event of a fire.

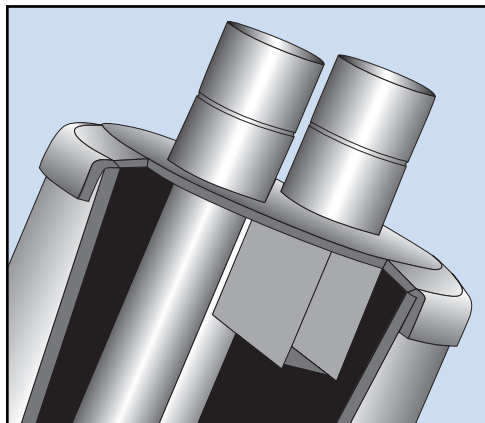

Figure 1

Typical accumulator with inlet deflector baffle.

Selection

Accumulator selection can be fine tuned for best performance. This involves the sizing of the accumulator and the sizing of the orifice. The controlling factor for both types is the type of metering device used in the system. In systems using a **fixed orifice**, the accumulator holding capacity should be about 70% of the system charge. This provides adequate holding capacity during operation with blocked or fouled heat exchanger coils. The resulting high discharge/low suction pressure condition will result in more liquid refrigerant in the accumulator. The oil return orifice size should be small to prevent excess liquid refrigerant being returned to the compressor. For these systems, a 0.040 inch diameter orifice is the recommended starting point.

Systems with a **thermostatic expansion valve (TEV)**, the accumulator holding capacity should be approximately 50% of the system charge. At startup and after defrost the bulb of the TEV is warm. Until the valve regains control, the accumulator plays a role in preventing liquid slugging of the compressor. The accumulator must also contend with off cycle refrigerant migration. At shut-down, the accumulator is the coldest component in the system. This results in migration of liquid refrigerant to the device. This type of system needs to return the refrigerant to circulation more quickly than the fixed orifice system. For these systems, a 0.055 inch diameter orifice allows quick return of the liquid refrigerant. The recommended sizes of the orifices can be further tested for optimum results. Other size orifices are possible to satisfy the characteristics required by the system designer.

New Refrigerants

The introduction of alternative refrigerants and oils requires reviewing the design of components within the system, including suction accumulators. As previously stated, the accumulator is the coldest component in the system. The new refrigerants and oils may or may not be fully miscible in the temperature range the accumulator normally operates. The oil and refrigerant can separate into oil rich and refrigerant rich layers in the accumulator, with the refrigerant rich layer at the bottom. The oil return orifice would be located in the refrigerant rich layer.

The solution to this problem is to provide active mixing of the layers in the accumulator. This is accomplished by the shape and position of the inlet deflector and outlet U-tube. The inlet flow stream is directed tangentially into the liquid layers in the bottom of the accumulator. The resulting circulation of the liquid past the off center U-tube forces a mixing of the oil and refrigerant layers.

Field Replacement

The accumulator should be changed when a compressor is replaced. The old accumulator may contain contaminants from the problem that caused the compressor failure. There may also be considerable oil remaining from the first compressor if a gradual loss of refrigerant caused the failure. This amount coupled with the oil in the replacement compressor may create an oil overcharge condition.

Steel Suction Line Accumulators

U-Tube Style Accumulators

The U-tube accumulator design is a result of extensive laboratory testing plus detailed investigation of the various accumulators currently available. It takes into account essential requirements such as safe holding volume (relative to the system's total charge), protected flow control for positive refrigerant and oil return, and minimum pressure drop across the accumulator.

Sporlan offers standard accumulator models designed for application on heat pump and refrigeration systems from 1/4 through 12 tons. Liquid refrigerant holding requirements of suction accumulator may vary by application. Because of the diversity in systems, optimum performance should be determined by the system designer. Consult Sporlan for assistance if required.

Features and Benefits

- Solid copper connections
- U-tube design for maximum flow of refrigerant and minimum oil entrapment
- Inlet flow deflector guides refrigerant toward wall for smooth tangential flow and gradual expansion
- U-tube entrance is positioned behind the inlet flow deflector to prevent unwanted liquid refrigerant from entering and damaging compressor
- Metering orifice matched to system capacity assures optimum liquid refrigerant and oil flow back to compressor
- Protective screen and orifice assembly on U-tube protects against contaminants affecting metering function
- Fittings and U-tube are matched to accumulator holding capacity and total system charge for minimum pressure drop and maximum refrigerant flow
- U.L. listed for 355 psig maximum working pressure. File No. SA5172
- Powder coating surpasses 500 hour ASTM salt spray
- Integral 430°F fuse plugs (U.L. File No. SA5441)

Also available:

Heat Exchanger Accumulator



- Can be integrated in all standard accumulators
- Copper coil for superior heat exchange
- Liquid line connections available in 3/8" ODF solder

Dimensions and Flow Data

Refer to page 3 for dimension values and flow data.

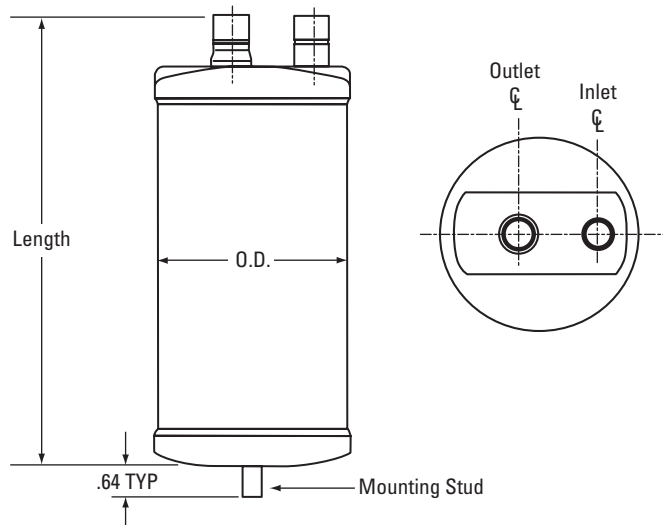

Steel Suction Line Accumulator Dimensions and Flow Data

Model No.	Conn. Inches (ODF)	Dimensions Inches		Capacity Ounces* (wt.)	Evap. Temp. °F	Recommended capacity in tons of refrigeration													
		Length	O.D.			22 & 404A		134a		401A		402A		407C		410A		502 & 507	
						Tons @ 1 psi	Min. Tons	Tons @ 1 psi	Min. Tons	Tons @ 1 psi	Min. Tons	Tons @ 1 psi	Min. Tons	Tons @ 1 psi	Min. Tons	Tons @ 1 psi	Min. Tons	Tons @ 1 psi	Min. Tons
PA3060-10-4 PA3060-10-5	1/2" 5/8"	10.35 10.35	3 3	35 35	40	2.00	0.35	1.67	0.30	1.42	0.25	1.97	1.01	1.97	0.46	1.93	1.44	1.48	0.27
					0	1.54	0.25	0.98	0.16	1.06	0.18	1.53	0.41	1.53	0.18	1.50	0.65	1.10	0.20
					-20	1.33	0.21	0.69	0.11	0.90	0.15	1.32	0.25	1.32	0.11	1.30	0.42	0.93	0.16
PA3060-15-5	5/8"	15.05	3	55	40	2.10	0.35	1.75	0.30	1.49	0.25	2.07	1.01	2.07	0.46	2.02	1.44	1.55	0.27
					0	1.62	0.25	1.03	0.16	1.11	0.18	1.61	0.41	1.60	0.18	1.57	0.65	1.16	0.20
					-20	1.40	0.21	0.73	0.11	0.95	0.15	1.39	0.25	1.39	0.11	1.36	0.42	0.98	0.16
PA3060-15-6	3/4"	15.05	3	54	40	2.30	0.35	1.92	0.30	1.63	0.25	2.27	1.01	2.27	0.46	2.22	1.44	1.70	0.27
					0	1.77	0.25	1.12	0.16	1.22	0.18	1.76	0.41	1.75	0.18	1.72	0.65	1.27	0.20
					-20	1.53	0.21	0.80	0.11	1.04	0.15	1.52	0.25	1.52	0.11	1.49	0.42	1.07	0.16
PA4065-9-5C	5/8"	9.62	4	60	40	2.96	0.35	2.47	0.30	2.10	0.25	2.92	1.01	2.92	0.46	2.85	1.44	2.19	0.27
					0	2.28	0.25	1.44	0.16	1.57	0.18	2.27	0.41	2.26	0.18	2.21	0.65	1.63	0.20
					-20	1.98	0.21	1.03	0.11	1.34	0.15	1.97	0.25	1.96	0.11	1.93	0.42	1.39	0.16
PA4065-9-6C	3/4"	9.62	4	58	40	3.00	0.35	2.53	0.30	2.10	0.25	2.96	1.01	2.96	0.46	2.89	1.44	2.20	0.28
					0	2.30	0.25	1.48	0.16	1.60	0.18	2.29	0.41	2.28	0.18	2.23	0.65	1.70	0.20
					-20	2.00	0.21	1.05	0.11	1.40	0.15	1.99	0.25	1.98	0.11	1.95	0.42	1.40	0.16
PA5083-9-6C	3/4"	9.62	5	89	40	3.82	0.57	3.19	0.49	2.71	0.41	3.76	1.51	3.77	0.69	3.68	2.16	2.82	0.46
					0	2.95	0.41	1.86	0.27	2.03	0.30	2.94	0.61	2.92	0.27	2.86	0.98	2.10	0.33
					-20	2.55	0.35	1.32	0.18	1.73	0.24	2.53	0.37	2.53	0.16	2.48	0.63	1.79	0.27
PA5083-9-7C	7/8"	9.63	5	86	40	3.90	0.57	3.21	0.49	2.70	0.41	3.84	1.51	3.85	0.69	3.76	2.16	2.80	0.46
					0	3.00	0.41	1.88	0.27	2.00	0.30	2.98	0.61	2.97	0.27	2.91	0.98	2.10	0.33
					-20	2.60	0.35	1.33	0.18	1.70	0.24	2.58	0.37	2.58	0.16	2.53	0.63	1.80	0.27
PA5083-12-7C	7/8"	12.88	5	125	40	5.41	0.88	4.51	0.75	3.83	0.64	5.33	2.12	5.34	0.96	5.21	3.03	4.00	0.70
					0	4.17	0.64	2.64	0.42	2.87	0.45	4.15	0.86	4.13	0.38	4.05	1.37	2.98	0.51
					-20	3.61	0.54	1.87	0.28	2.45	0.37	3.59	0.52	3.58	0.22	3.52	0.88	2.53	0.41
PA5083-11-7C	7/8"	11.33	5	108	40	4.38	0.57	3.21	0.43	3.10	0.41	4.32	1.51	4.32	0.69	4.22	2.16	3.23	0.46
					0	3.37	0.41	1.88	0.24	2.32	0.30	3.35	0.61	3.34	0.27	3.27	0.98	2.41	0.33
					-20	2.92	0.35	1.33	0.16	1.98	0.24	2.90	0.57	2.89	0.16	2.84	0.63	2.04	0.27
PA5083-11-6C	3/4"	11.33	5	111	40	3.85	0.57	3.21	0.49	2.72	0.41	3.79	1.51	3.80	0.69	3.71	2.16	2.84	0.46
					0	2.97	0.41	1.88	0.27	2.04	0.30	2.96	0.61	2.94	0.27	2.88	0.98	2.12	0.33
					-20	2.56	0.35	1.33	0.18	1.74	0.24	2.54	0.57	2.54	0.16	2.49	0.63	1.80	0.27
PA5083-15-7C	7/8"	15.34	5	156	40	6.20	0.88	5.17	0.75	4.39	0.64	6.11	2.12	6.12	0.96	5.97	3.03	4.58	0.70
					0	4.78	0.64	3.03	0.42	3.29	0.45	4.76	0.86	4.73	0.38	4.64	1.37	3.41	0.51
					-20	4.13	0.54	2.15	0.28	2.80	0.37	4.10	0.52	4.09	0.22	4.02	0.88	2.90	0.41
PA5083-17-7C	7/8"	17.25	5	179	40	6.20	0.88	5.17	0.75	4.39	0.64	6.11	2.12	6.12	0.96	5.97	3.03	4.58	0.70
					0	4.78	0.64	3.03	0.42	3.27	0.45	4.76	0.86	4.73	0.38	4.64	1.37	3.41	0.51
					-20	4.13	0.54	2.15	0.28	2.80	0.37	4.10	0.52	4.09	0.22	4.02	0.88	2.90	0.41
PA6125-15-9C	1-1/8"	15.00	6	211	40	9.00	3.00	8.83	1.97	6.10	1.90	8.87	3.45	8.88	1.57	8.67	4.93	7.30	3.00
					0	5.60	2.00	5.62	0.82	3.70	1.20	5.57	1.40	5.55	0.62	5.44	2.23	4.50	2.00
					-20	4.30	0.80	4.31	0.50	2.80	0.05	4.27	0.85	4.26	0.36	4.19	1.43	3.40	0.80
PA6125-15-11C	1-3/8"	15.25	6	214	40	12.00	3.00	12.05	1.97	6.20	1.90	11.82	3.45	11.85	1.57	11.56	4.93	9.80	3.00
					0	7.50	2.00	7.52	0.82	5.00	1.20	7.46	1.40	7.43	0.62	7.28	2.23	6.00	2.00
					-20	5.80	0.80	5.82	0.50	3.60	0.05	5.76	0.85	5.75	0.36	5.65	1.43	4.60	0.80
PA6125-18-9C	1-1/8"	18.00	6	264	40	8.80	3.00	8.84	1.97	6.00	1.90	8.67	3.45	8.69	1.57	8.48	4.93	7.20	3.00
					0	5.50	2.00	5.52	0.82	3.70	1.20	5.47	1.40	5.45	0.62	5.34	2.23	4.40	2.00
					-20	4.30	0.80	4.31	0.50	2.80	0.05	4.27	0.85	4.26	0.36	4.19	1.43	3.40	0.80
PA6125-18-11C	1-3/8"	18.00	6	267	40	11.00	3.00	11.05	1.97	7.50	1.90	10.84	3.45	10.86	1.57	10.59	4.93	9.10	3.00
					0	7.00	2.00	7.02	0.82	4.60	1.20	6.96	1.40	6.93	0.62	6.80	2.23	5.50	2.00
					-20	5.40	0.80	5.42	0.50	3.50	0.05	5.37	0.85	5.35	0.36	5.26	1.43	4.20	0.80
PA6125-20-11C	1-3/8"	20.25	6	302	40	11.00	3.00	11.05	1.97	7.50	1.90	10.84	3.45	10.86	1.57	10.59	4.93	9.10	3.00
					0	7.00	2.00	7.02	0.82	4.60	1.20	6.96	1.40	6.93	0.62	6.80	2.23	5.50	2.00
					-20	5.40	0.80	5.42	0.50	3.50	0.05	5.37	0.85	5.35	0.36	5.26	1.43	4.20	0.80

* Holding capacity of R-22 at 40°F. Divide by 0.7 to obtain recommended maximum system charge on fixed orifice systems. Consult Sporlan for availability.

Stand Pipe Style Steel Accumulators

Features and Benefits

- Available in 2-1/2, 3 and 4 inch diameters
- Copper and copper plated steel fittings
- Standard fitting sizes: 3/4 ODF and 7/8 ODF
other sizes available upon request
- Dual screened orifice design, various orifice sizes available
- U.L. listed file no. SA5172, CSA certified

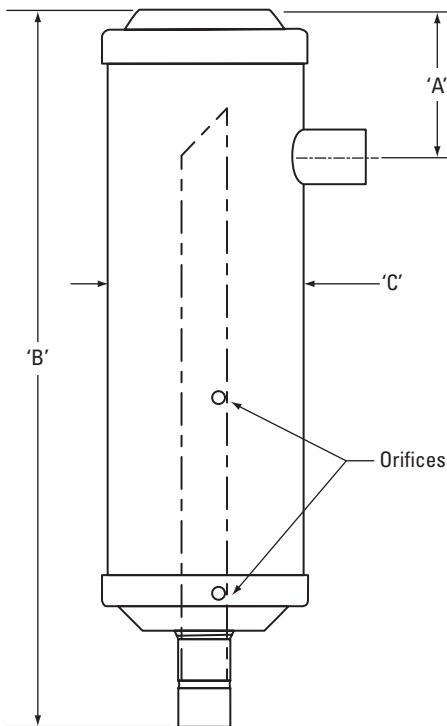

Model Number	Connection Size Inches	'A'	'B'	'C'	Orifice Diameter Inches	Volume Cubic Inches
P3060-11-6C	3/4 ODF	2.25	11.00	3.00	0.060	41.5
P3060-13-7C	7/8 ODF	2.25	13.00	3.00	0.060	50.0
P3060-13-7C	7/8 ODF	2.25	13.00	3.00	0.035	50.0



Sporlan Division
Parker Hannifin Corporation
206 Lange Drive
Washington, MO 63090
636-239-1111 • FAX 636-239-9130
www.sporlan.com