

EXTREME PERFORMANCE
FOR EXTREME CONDITIONS

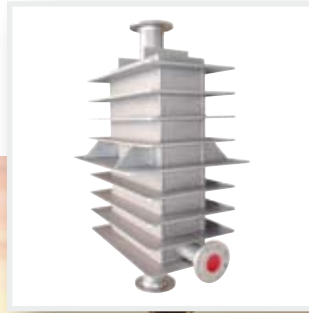

SUPERMAX[®]
Welded Plate Heat Exchanger

MAXCHANGER[®]
Welded Plate Heat Exchanger



Plate Heat Exchanger Performance at Shell & Tube Pressures

Tranter's SUPERMAX® and MAXCHANGER® Welded Plate Heat Exchangers require only a fraction of the space of the equivalent shell & tube exchangers. The compact plates also produce a high performance due to the turbulent flow created by the corrugated and dimpled plate patterns. This high efficiency allows Tranter to design units with a 1°C temperature approach. Another benefit is the small hold-up volume which offers fast start-up times and close following of process changes.

The advantages of the SUPERMAX® and MAXCHANGER® can be applied to challenging application involving liquids, gases, steam and two-phase mixtures. This includes aggressive media, organic solvents, steam heaters and as interchangers which are beyond the capability of traditional Gasketed Plate & Frame Heat Exchangers.

Tranter's all-welded manufacturing facilities are located in Artern; Germany, Wichita Falls; USA and Pune; India. The factories are ISO certified adhering to the highest standards in the design, manufacturing and testing of plate heat exchangers.



Applications

Oil & Gas Production and Refining

- Optimisation of heat recovery, cooling, condensation, dehydration and reboiling systems; usable with gas, light and heavy products
- Applications with distillation columns, fractionators, hydrocrackers, recrackers, hydrogen sulphide strippers and similar systems
- Waste heat recovery applied to feed water heating
- LPG reliquefaction

Chemical Processing

- Optimisation of condensation, heating/cooling, heat recovery and reboiling systems
- Applications with organics such as olefins, aromatics, alcohols, aldehydes, ketones, acids, ethers, esters, nitriles or sulphones, including halogenated compounds
- Applications with mineral acids and caustics, such as heating and cooling with heat recovery
- Viscous processing with monomers and resins
- Soaps and detergents, paints and coatings
- Mineral oil heating and cooling
- Gas cooling and drying: chlorine, hydrogen, nitrogen, carbon dioxide
- Vapour and solvent recovery

Pharmaceuticals & Speciality Chemicals

- Multifunction units for condensing and mist elimination
- Gas condensation with hygienic design
- Vapour and solvent recovery

Emissions Control Systems

- Ammonia liquor scrubber cooling

HVAC, District Heating, Energy, Utilities, General Services

- Hot water production system
- Steam heating
- Heat recovery
- Desuperheaters in heat recovery
- High temperature interchanger
- Evaporators and condensers for refrigeration duties, with all types of refrigerants

Food Processing

- Vegetable oil processing

Power Generation

- Low pressure feed-water heaters
- Condensate exchangers
- Boiler blow-down
- Condensers
- Evaporators
- Molten salt to Dowtherm interchangers



SUPERMAX®

The Tranter SUPERMAX® shell & plate heat exchanger is designed for pressures of 100 bar and above, and temperatures up to 900°C.

The SUPERMAX® can be installed horizontally or vertically depending on application and customer preference. We recommend horizontal installation for condensing / evaporating / boiling applications.

The chevron-type plates are fabricated into a cassette by full automatic welding in the port hole (1). These cassettes are then stacked together and perimeter welded to each other (2), producing an accordion-like core which is highly tolerant to thermal expansion.

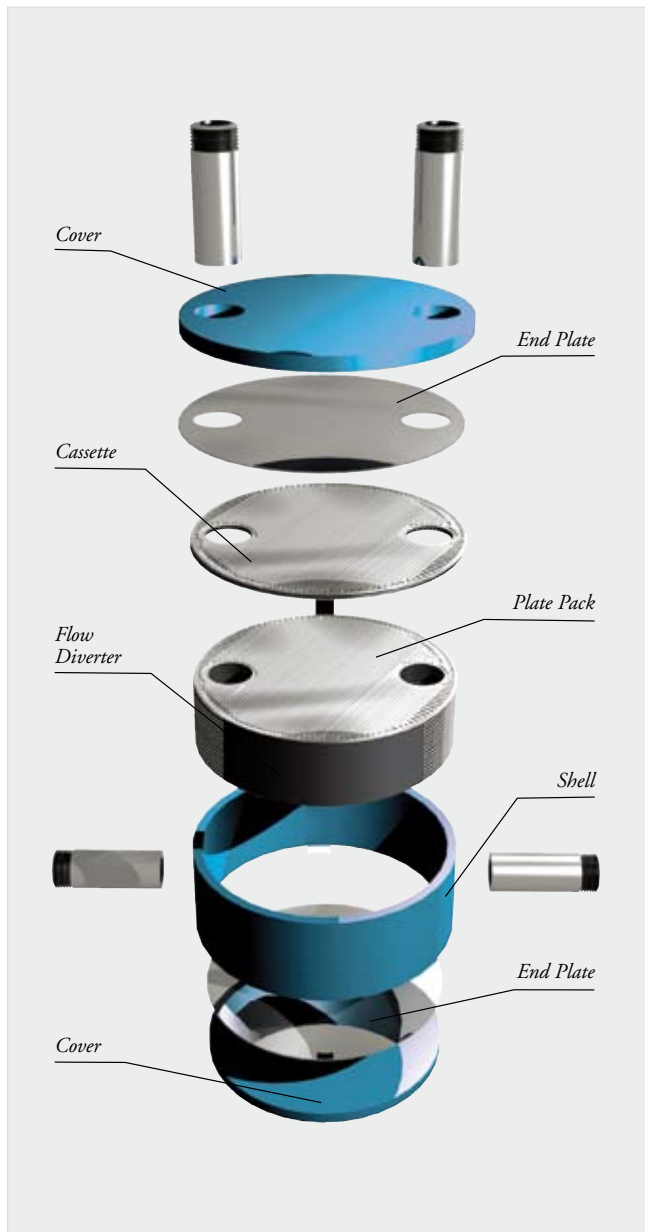

The plate pack is then inserted in a cylindrical shell. The shell and plate pack are fitted with special fluid diverters to ensure proper flow throughout the unit. End plates, connections and top & bottom covers are welded to the shell to form a pressure vessel of high integrity. Extra large connection sizes can be selected on the shell side of the heat exchanger.

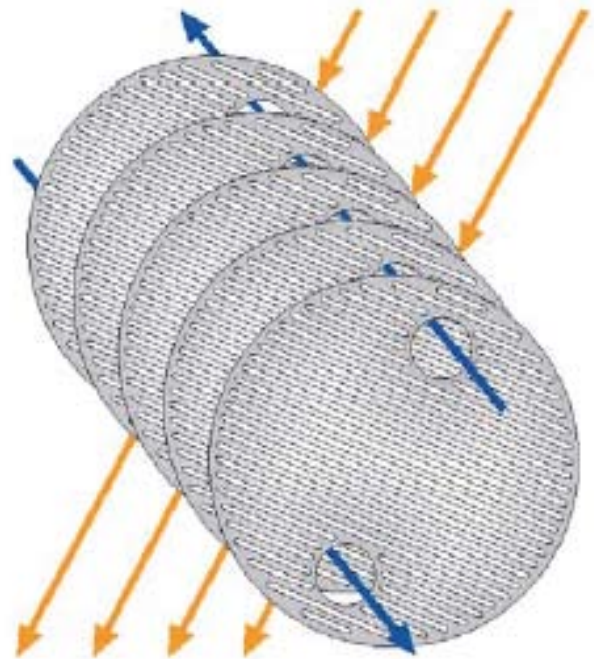

The plates are adjusted within the shell to optimise flow distribution and performance. SUPERMAX® units can be designed in for co-current, counter-current and cross-flow duties. Plates can also be arranged to form multiple passes.

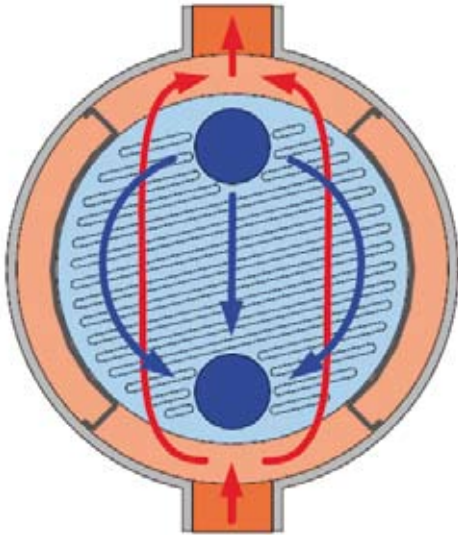

Flow distribution on the shell side (red) and on the plate side (blue).

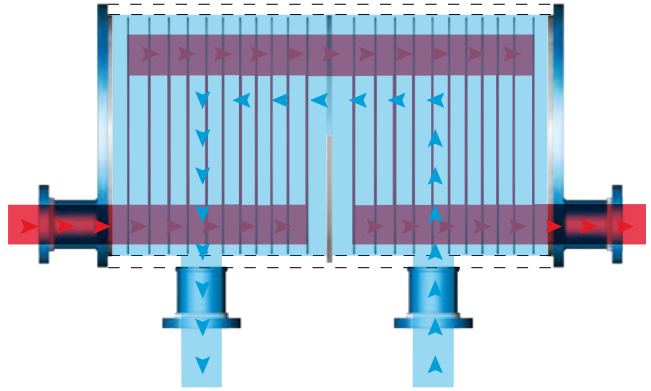

SUPERMAX® plates can be arranged to form multi passes on both the plate and shell sides.

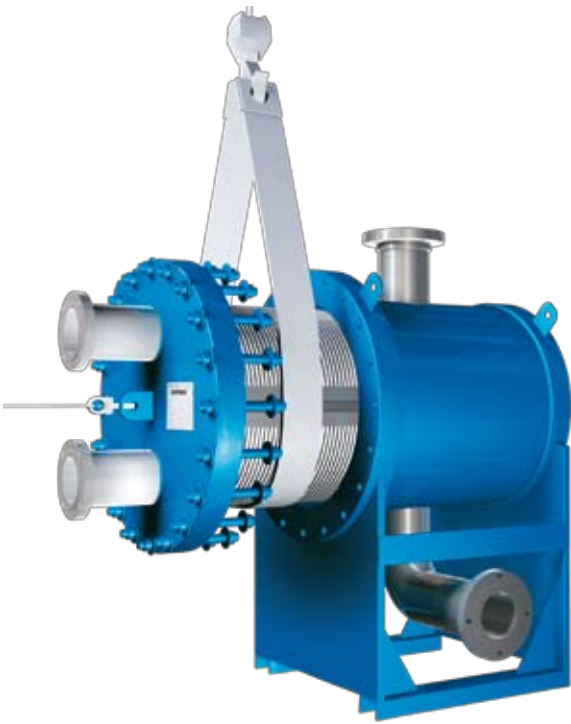

The SUPERMAX® with removable core provides full access to the plate pack for inspection and/or mechanical cleaning.



SUPERMAX® plates can be manufactured from Stainless Steel 316L, 254 SMO, Hastelloy and Titanium as standard; other alloys also available. The Shell can be fabricated from a differing material when only one side will be exposed to corrosive conditions.

SUPERMAX® SPW, OPW, DPW and MAXCHANGER® Plate Range

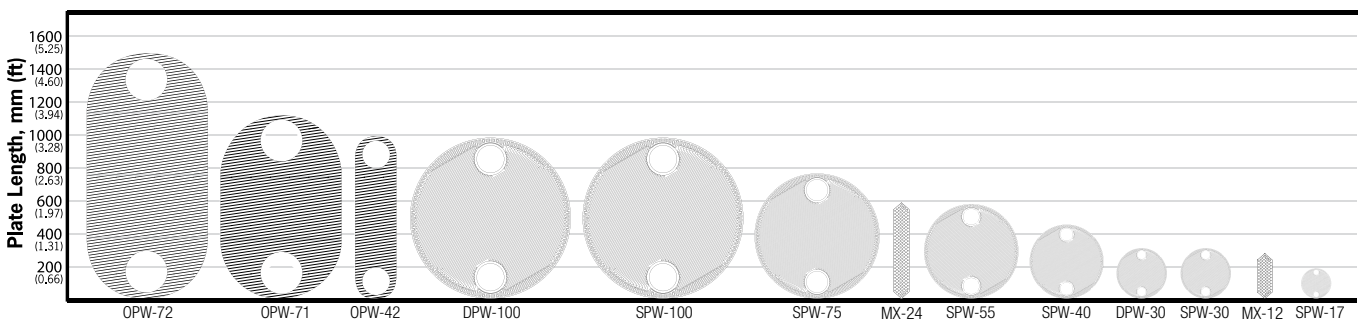



SPW & DPW- The Round Plates

SUPERMAX® SPW & DPW units are available in a variety of versions dependant on application. These are:

- fully-welded with a centric plate pack
- fully-welded with an eccentric plate pack (evaporators)
- removable core for access to the shell side
- two plate packs in one shell



SPW & DPW Plate Dimensions and Available Connections¹

Type	SPW-17	SPW/DPW-30 ²	SPW-40	SPW-55	SPW-75	SPW/DPW-100 ²
Connection plate side (DN)	25	50	80	100	150	200
Connection shell side (DN)	10-100	20-150	25-250	32-350	50-500	100-700

¹Dual inlets on both plate and shell are available. ²Deep draw depth plate.



Full-welded SPW-75 with Stainless Steel 316 plates and Carbon Steel shell (painted finish) for steam condensing in a district heating system.



SPW-75 with two removable cores housed in one shell. Full Stainless Steel 316L construction.



Removable core SPW-55 designed as a cooler for the Chemical Industry. Plates and shell manufactured in 254 SMO.



OPW- The Oblong Plate

SUPERMAX® oblong plates are used with duties requiring long thermal lengths and / or small log mean temperatures (LMTD).

They can be supplied in a variety of designs:

- fully welded with reinforced ribs
- fully welded core with pressure plates and frame
- removable core with access to plate pack

OPW Plate Dimensions and Available Connections¹

Type	OPW-42	OPW-71	OPW-72
Surface (m ²)	0,22	~0,7	~1,0
Connection plate side (DN)	80	250	250
Connection shell side (DN)	10-150	10-500	10-500

¹Dual inlets on both plate and shell are available.

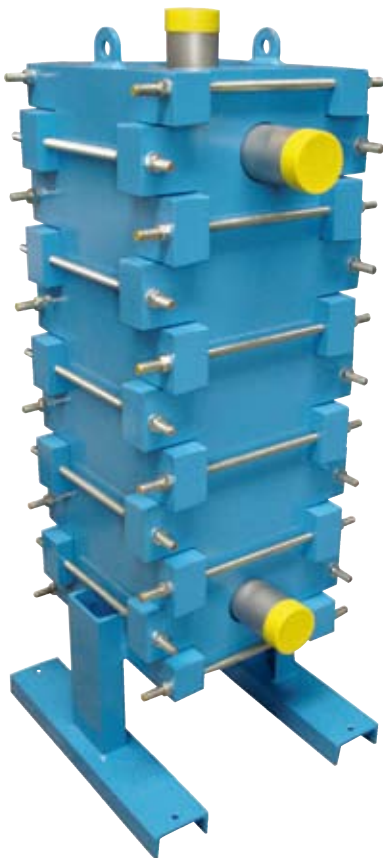
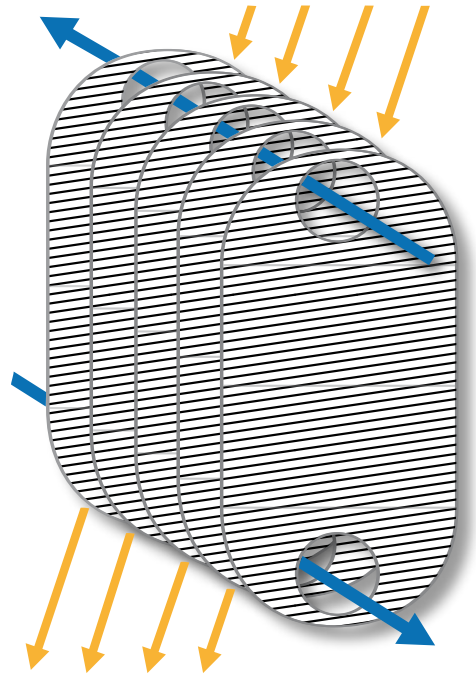

OPW-42 Fully-welded Stainless Steel 316L core with Carbon Steel pressure plates. Hot and Cold fluids will only come into contact with Stainless Steel 316 parts so ideal for corrosive media. Carbon Steel parts help reduce construction costs!

Operating temperatures: -50 to 250°C

Operating pressure: up to 40 bar



Fully-welded OPW-42 with reinforced ribbing. Two-pass design in full Stainless Steel 316L construction.



Refrigeration Systems & Applications

Tranter Pressko designs and builds complete skids for the refrigeration industry. The skids include the SUPERMAX® heat exchanger and all ancillary parts.



Two SPW-55 R507 evaporators in parallel with separator. Skid for a Climate Testing Laboratory supplied to the Automotive Industry.



SPW-55 Ammonia evaporator with separator. Skid for cooling machinery in the Plastics Industry.

MAXCHANGER®

MAXCHANGER® Welded Plate Heat Exchangers provide a high heat transfer rate in a very compact space. They are designed for challenging applications involving liquids, gases, steam and two-phase mixtures at high temperatures and pressures.

The MAXCHANGER® dimpled 316L SS or titanium plates are arranged alternately and welded together at the sides to form channels for hot and cold media. Spacers isolate the channels and induce countercurrent flow. The numerous dimples provide maximum pressure resistance and heat transfer. Corner angles or half-pipes are welded to the plate pack points and to the top and bottom plates, forming inlet and outlet headers.

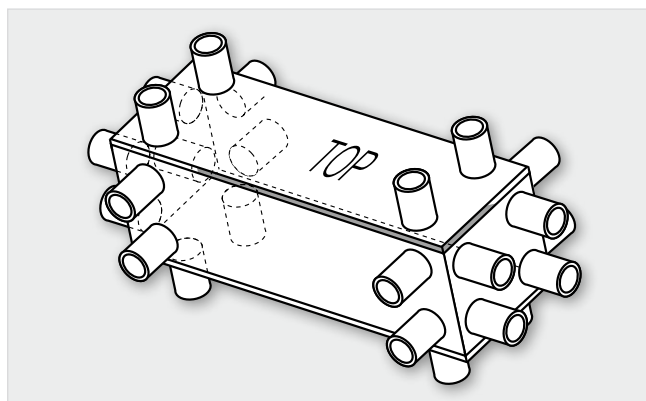
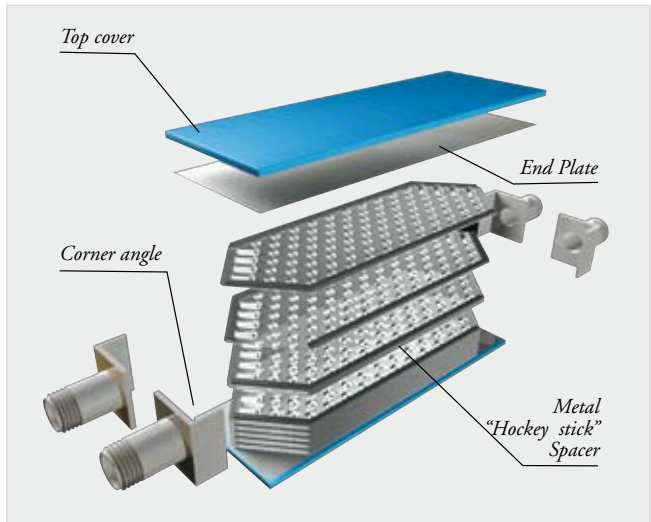

MAXCHANGER® connection type and orientation can be configured to suit customer requirements. Connections can be located on the front, back, side and top or bottom, corner connections are also possible.

Standard materials: Stainless Steel 316L & Titanium

Operating temperatures: -50°C to 540°C

Operating pressure: up to 115 bar



At the forefront of welded heat exchanger technology for more than 15 years

Tranter has been supplying all-welded products since 1993. The welded manufacturing facilities are located in America (USA), Asia (India) and Europe (Germany). All factories are ISO certified adhering to the highest standards in the design, manufacturing and testing of plate heat exchangers. Tranter Pressko GmbH originated from Tranter's acquisition of Pressko AG in 2008. Pressko AG was founded in 2000 and has been delivering top quality shell & plate heat exchangers worldwide for almost a decade.

Tranter is constantly developing its welded products and expanding the product line to meet customer demands. Contact us for a qualified discussion of your needs.



Europe

Tranter Pressko GmbH
Artern, Germany
Tel: +49 34 66 740 160
Fax: +49 34 66 740 168
E-mail: info@se.tranter.com,
pressko@de.tranter.com

North & South America

Tranter, Inc.
Wichita Falls, TX USA
Tel: +1 940 723 7125
Fax: +1 940 723 5131
E-mail: sales@tranter.com

Middle East/Africa/Asia

Tranter India Pvt. Ltd.
Pune, India
Tel: +91 2137 392300
Fax: +91 2137 392354
E-mail: sales@in.tranter.com

Up-to-date contact information to our local sales offices is always available on our website:

www.tranter.com